

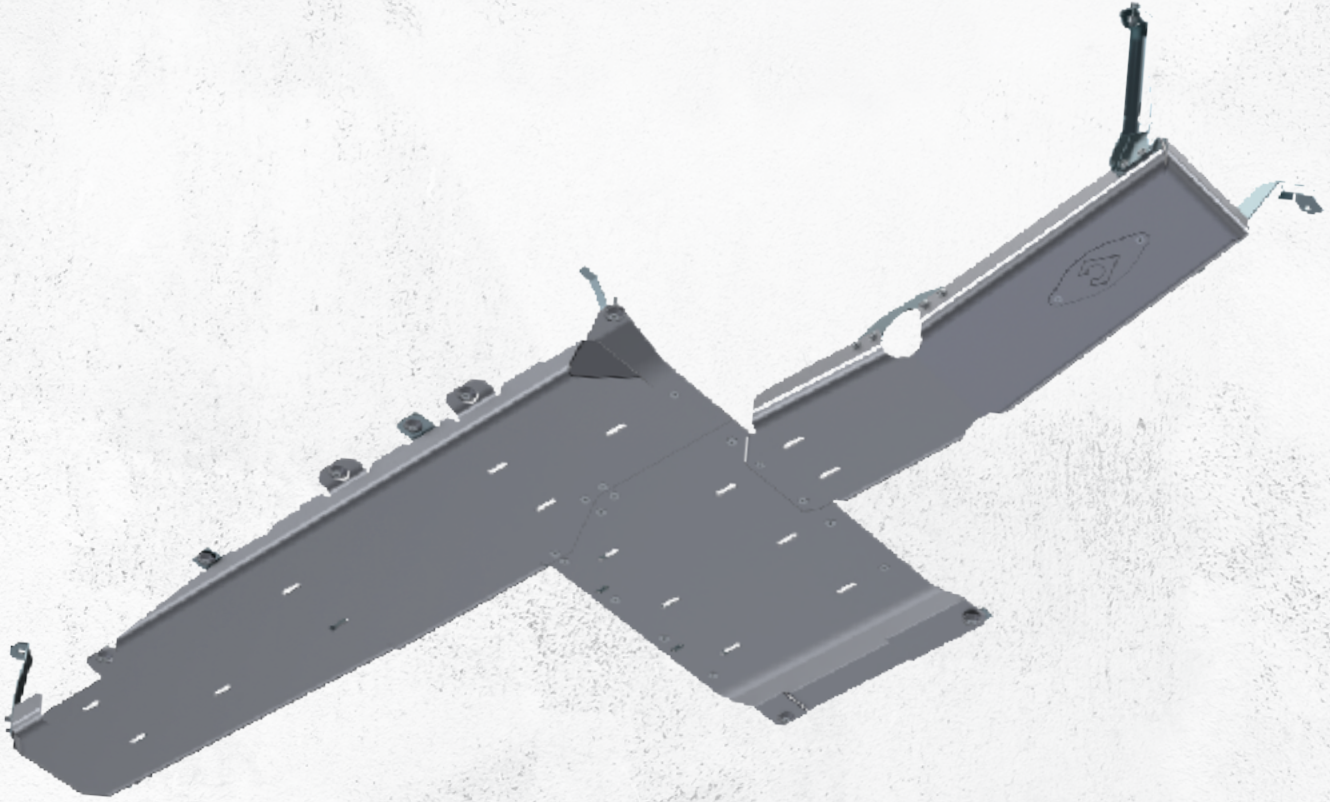

## PART # JT4155

### JT FULL BELLY PAN WITH OIL DOOR - 3.6L GAS ENGINE ALUMINUM INSTALLATION INSTRUCTIONS



#### ESTIMATED INSTALLATION TIME

3-5 hours

#### REQUIRED SKILLS

- General Mechanics Skills
- Drilling

#### REQUIRED TOOLS & SUPPLIES

- 18mm socket
- 17mm socket
- 15mm socket
- 13mm socket
- 13mm wrench
- Ratchet strap
- 9/16 inch wrench
- 9/16 inch socket
- Electrical tape
- 7/32 inch Allen wrench
- Ratchet extension 2 inch
- Ratchet extension 6 inch
- Screw driver
- Flat pry bar
- Safety glasses
- Pliers/vice grips
- Screw driver flathead
- Jack/vehicle lift (optional)
- 13mm ratchet wrench (optional)

#### NOTES:

- This kit replaces original SKU JT4150
- This product arrives in 4 separate boxes labeled BP1729, BP1678, BP1675, and BP1482.D
- Component appearance in instructions may vary from those received

## WARNING MESSAGES

This product demands a basic understanding of mechanical procedures and should only be installed by individuals proficient with mechanic's tools. Any tasks involving welding or cutting parts should be performed by trained professionals. Artec Industries disclaims responsibility for mishaps arising from improper installation, or any damage or accidents resulting from cutting or welding tasks. Exercise caution and seek professional help as required

## SAFETY

1. We've furnished a written installation guide, along with relevant details, to aid you in making safety-conscious decisions.
2. While these guidelines will highlight potential risks, it's crucial to exercise your personal judgment when performing any required steps.
3. Before initiating any tasks, it's essential to conduct a job safety analysis to identify specific hazards in your situation and take measures to eliminate or protect against them.
4. Before commencing the installation of this product, make sure you familiarize yourself with and fully understand all safety warnings and guidelines.

## DISCLAIMERS

All Artec Industries products should be installed by a competent, certified individual following the intended installation instructions for each product. Incorrect installations not only nullify any warranties but could also lead to product damage or even damage to the vehicle it's installed on. Prior to installation, carefully read all provided instructions or manuals, and watch any associated videos. For any doubts or queries, reach out to Artec Industries before beginning the installation process.

Many products necessitate lifting and supporting the vehicle off the ground. It is the installer's responsibility to ensure this can be done safely and that the right equipment is at hand to carry out the installation. Artec Industries installation instructions presume the installer is competent to lift the vehicle safely and correctly.

Modified vehicles won't perform identically to their stock counterparts. It's incumbent upon the vehicle owner to understand the alterations such modifications will bring to the vehicle's driving dynamics. These might encompass (but aren't limited to): changes in handling, braking, rollover angle, and potential incompatibilities with the factory-installed anti-lock braking systems, stability control systems, or traction control systems.

## SPECIAL NOTES

- This product requires removal of the factory fuel tank skid which supports the plastic fuel tank. Prior to beginning installation, ensure that you have 1/4 tank of fuel or less in the vehicle.
- Unless otherwise noted, all hardware should be **LOOSELY** installed by hand until the very end of installation when all components are attached.

## JT4155 PARTS BILL OF MATERIALS

Please confirm you have all the listed parts below BEFORE beginning your installation. If any parts are damaged or missing, KEEP ALL ORIGINAL BOXES and PACKAGING and contact us.

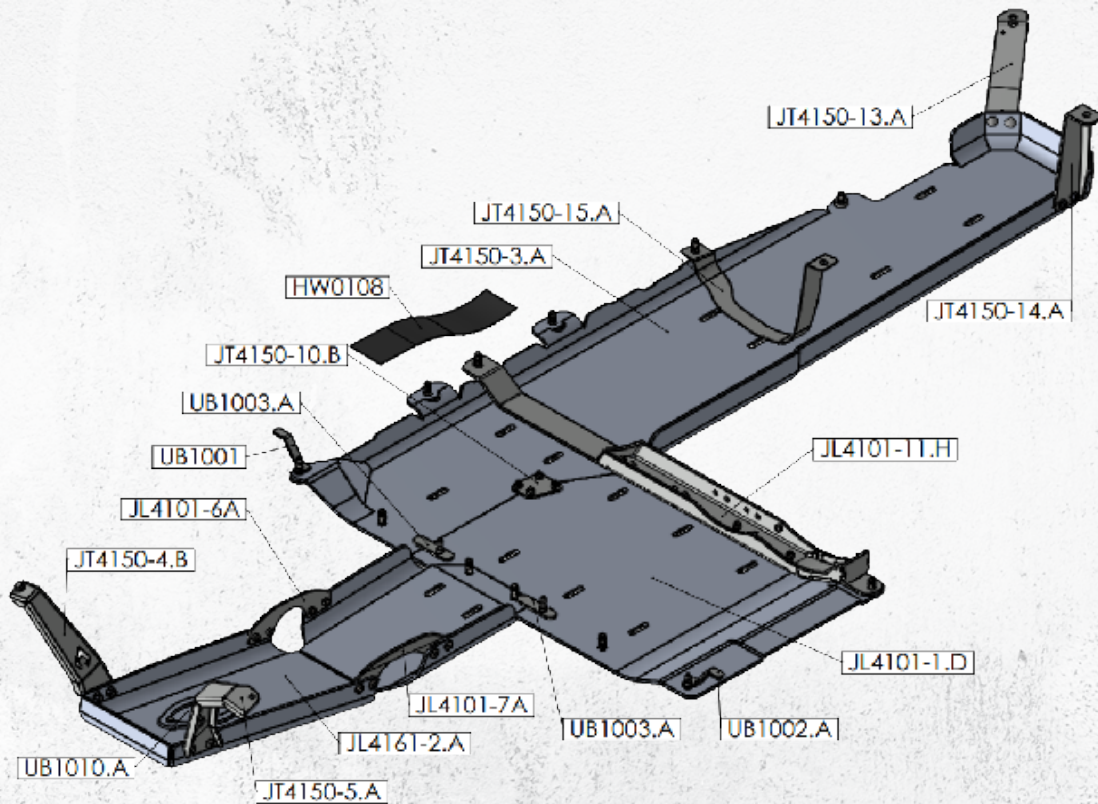

**NOTE:** The part numbers indicated above end in a "." and "letter" which indicate the revision number for the part. The etched part number on your physical parts do not need to match the above drawing revision exactly.

## HK4150 HARDWARE BILL OF MATERIALS

PART NUMBER	DESCRIPTION	QTY.
HW0019	3/8"-16 Nylock Insert Hex Nut Clear Zinc	8
HW0035	3/8" 16 x .75" long button head screws ZINC plated	6
HW0059	3/8" Flat Washer Type 1 Yellow Zinc	18
HW0061	3/8 x 1 flat head bolt	11
HW0101	3/8 x 16 x 1 Button Head Cap Screw Alloy Steel Zinc Plated	4
HW0105	3/8 x 1in carriage bolt	4
HW0135	M10 x 1.5mm - Flange Lock Nut	1
HW0136	M10 - 1.5 x 40mm long Hex Head Bolt	1
HW0137	M10 washer	1
HW0141	CUSTOM M12 - 1.5 x 40mm long flat head	11
HW0147	.375" Countersunk Aluminum Washer	8
HW0187	3/8 in x 2 in Counter Sink Allen Head Bolt - ZINC PLATED	4
SP1005	Aluminum Spacer .4" thick, 1.0" OD, .52" ID	1

STEP LOCATION GUIDE

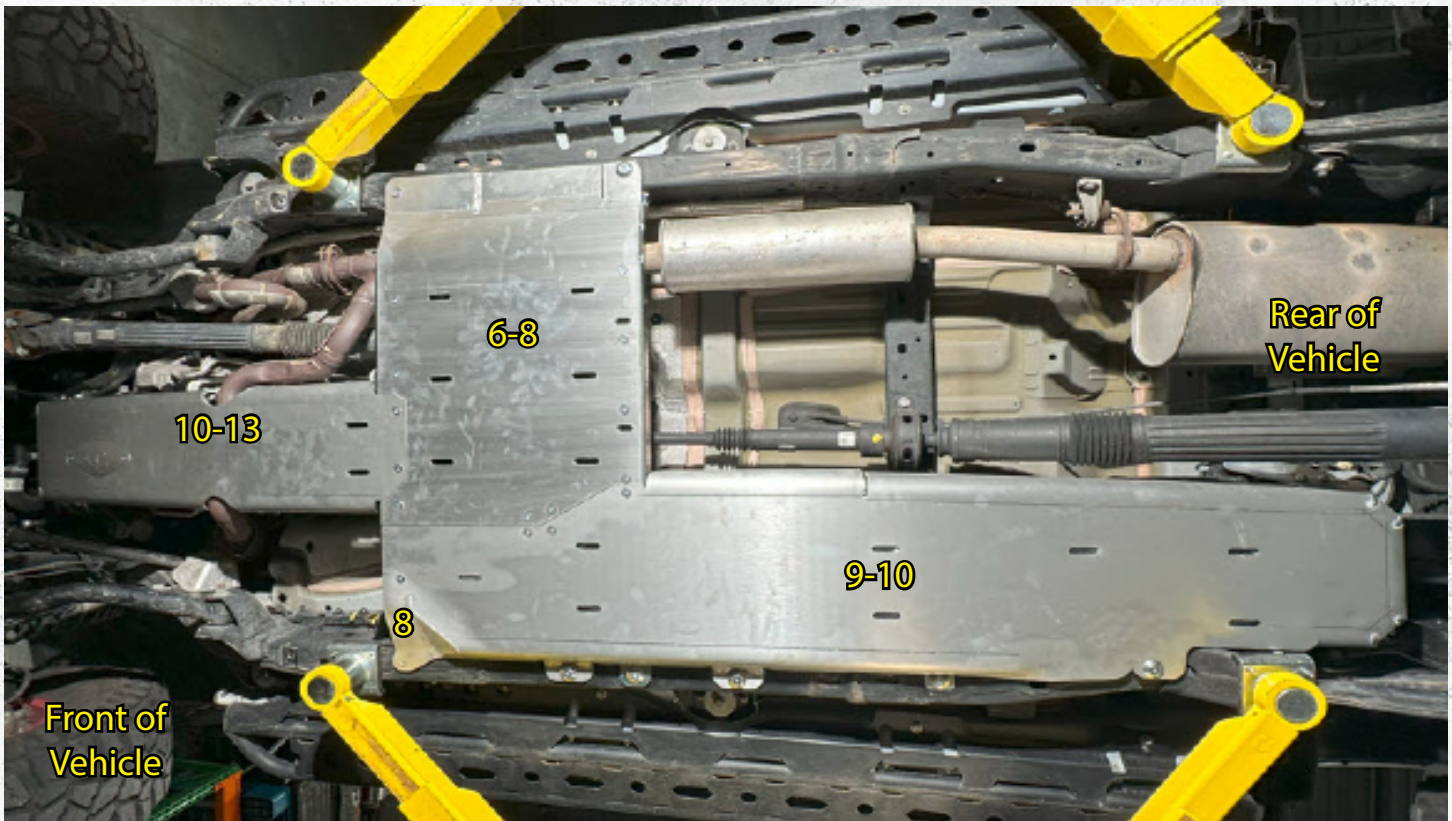
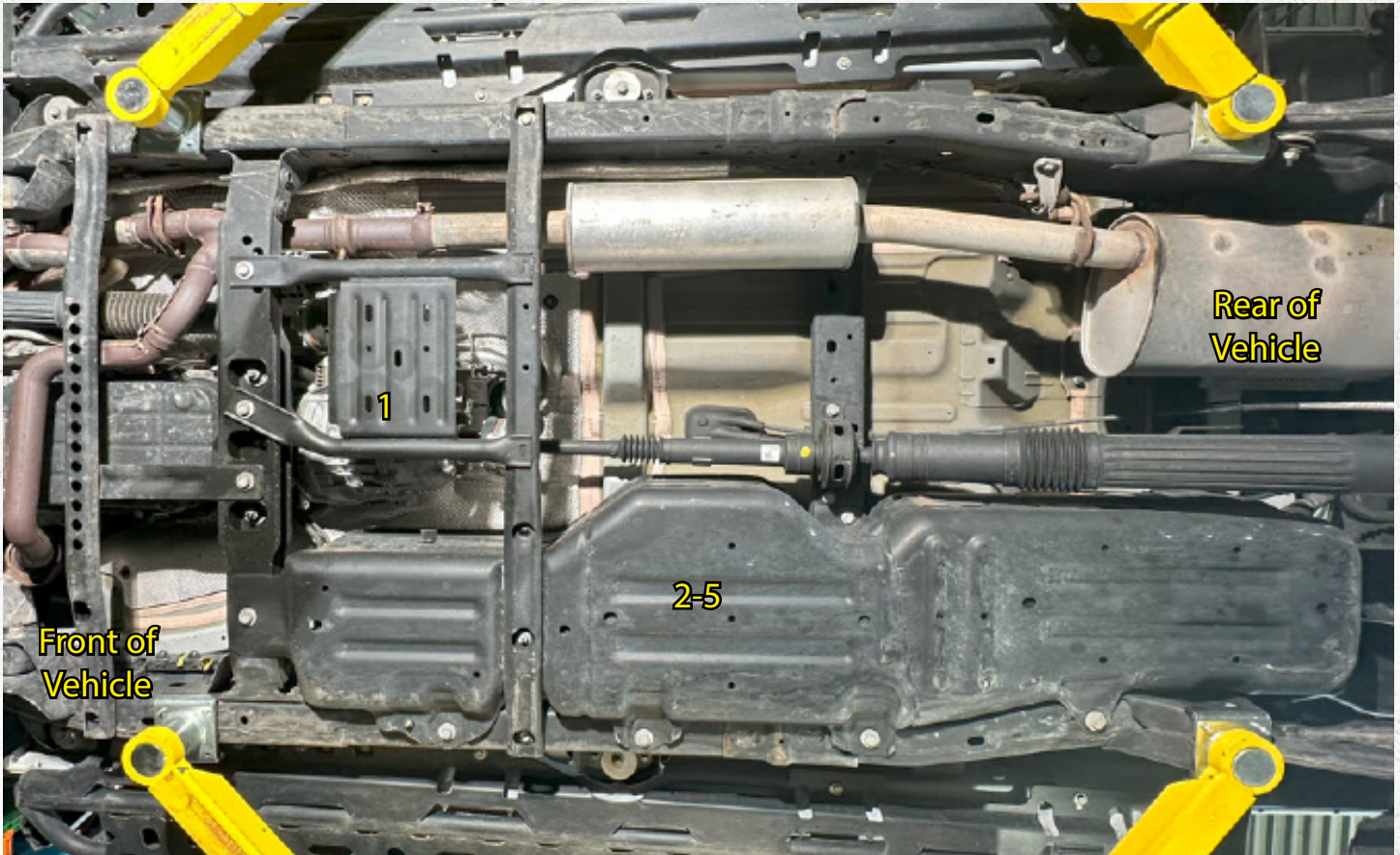

## DISASSEMBLY INSTRUCTIONAL GUIDE

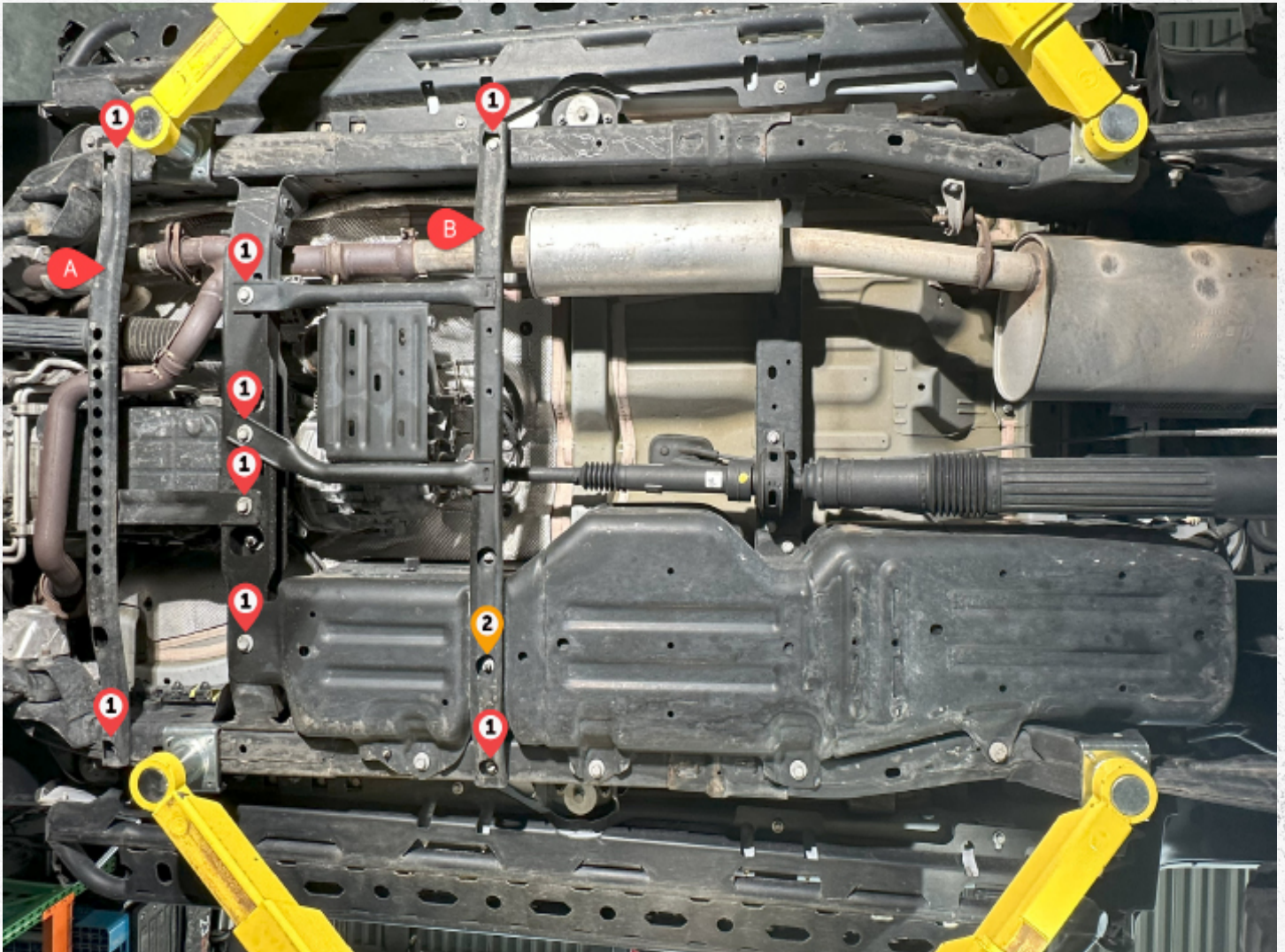

Step 1:

A: Remove the transmission skid by removing 3 - 12mm bolts **1** using a 18mm socket.

B: Remove transfer case & exhaust skid by removing 1 - 8mm bolts **2** using 13mm socket AND 4 - 12mm bolts **1** using a 18mm socket.

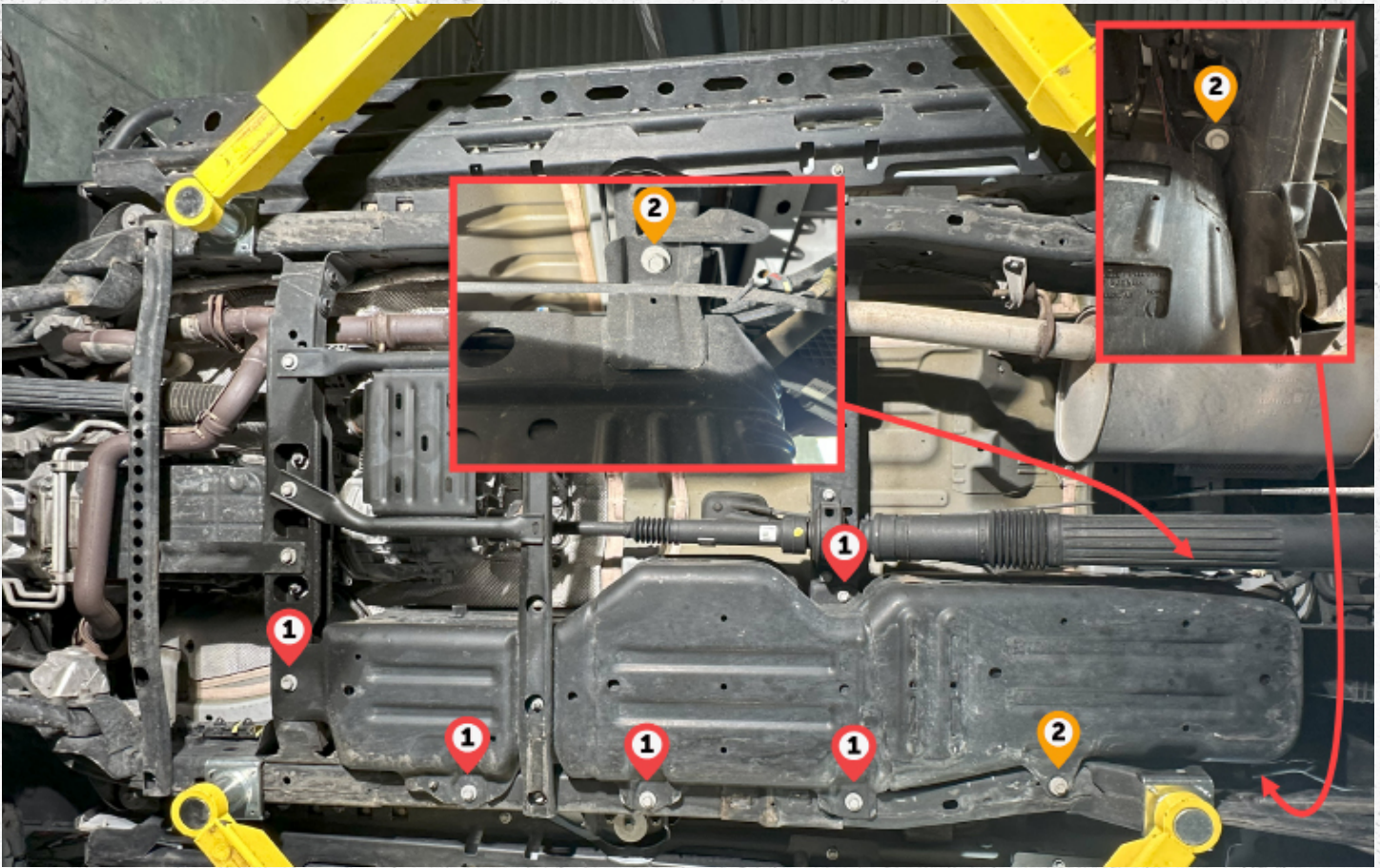

Step 2:

A: Remove fuel tank skid by removing 5 - 12mm bolts **1** using a 18mm socket.

B: Loosen 3 - 12mm bolts **2** using the same 18mm socket.

C: Detach the clips holding the fuel lines to fuel tank skid

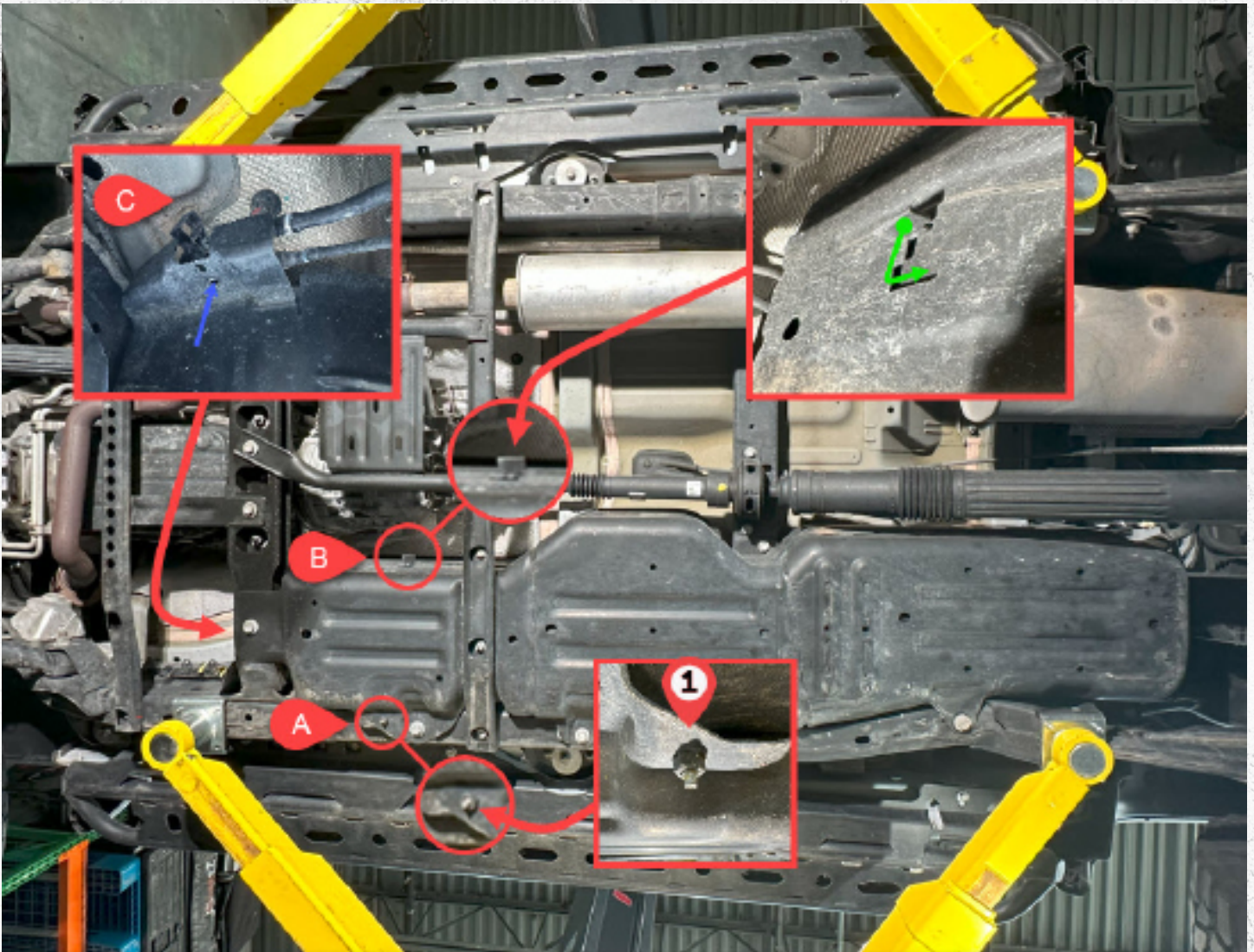

Step 3:

A: Remove 1 - M8 bolt **1** using a 13mm wrench/socket.

B: Using pliers or vise grip pull this tab down and push through the slot to disengage it (**GREEN**) arrow

C: Disconnect the fuel line from the front of the factory fuel tank skip by pushing the Christmas tree

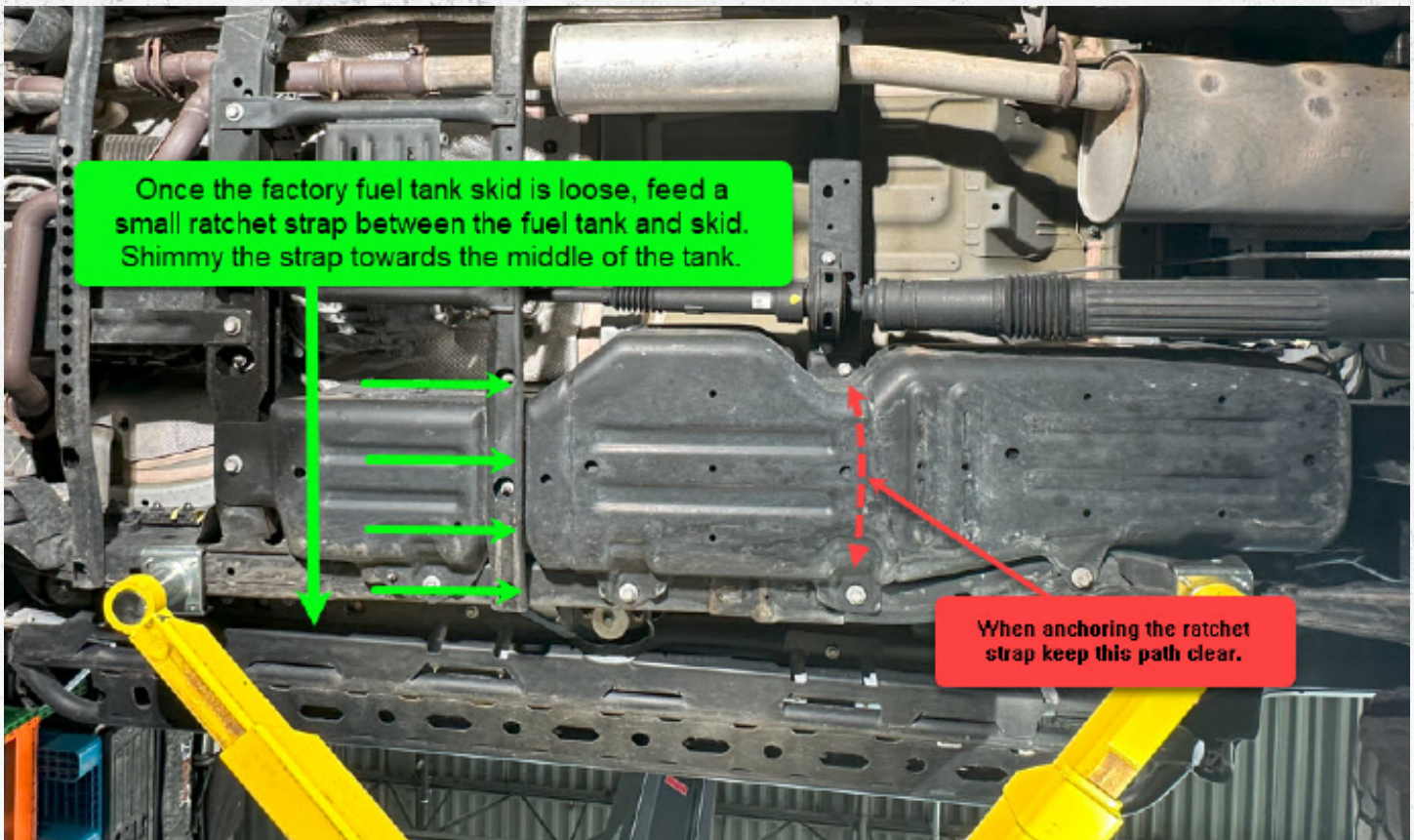

Step 4. Using a small ratchet strap you will suspend the tank so that you can remove the factory fuel tank skid. Make sure to anchor the ratchet strap to something substantial. After suspending the tank you can remove the fuel tank skid. This can take some time, and can be frustrating but it is necessary. Having less than 1/4 tank of fuel helps here.

**SAFETY NOTE:** When manipulating the skid and fuel tank, be careful not to damage or puncture the fuel tank. The fuel tank skid can be heavy and awkward to drop. Have a second person assist or use a jack to support the skid as you remove it. Ensure the ratchet strap is securely holding the fuel tank in place before attempting to remove the skid plate.

## ASSEMBLY INSTRUCTIONAL GUIDE

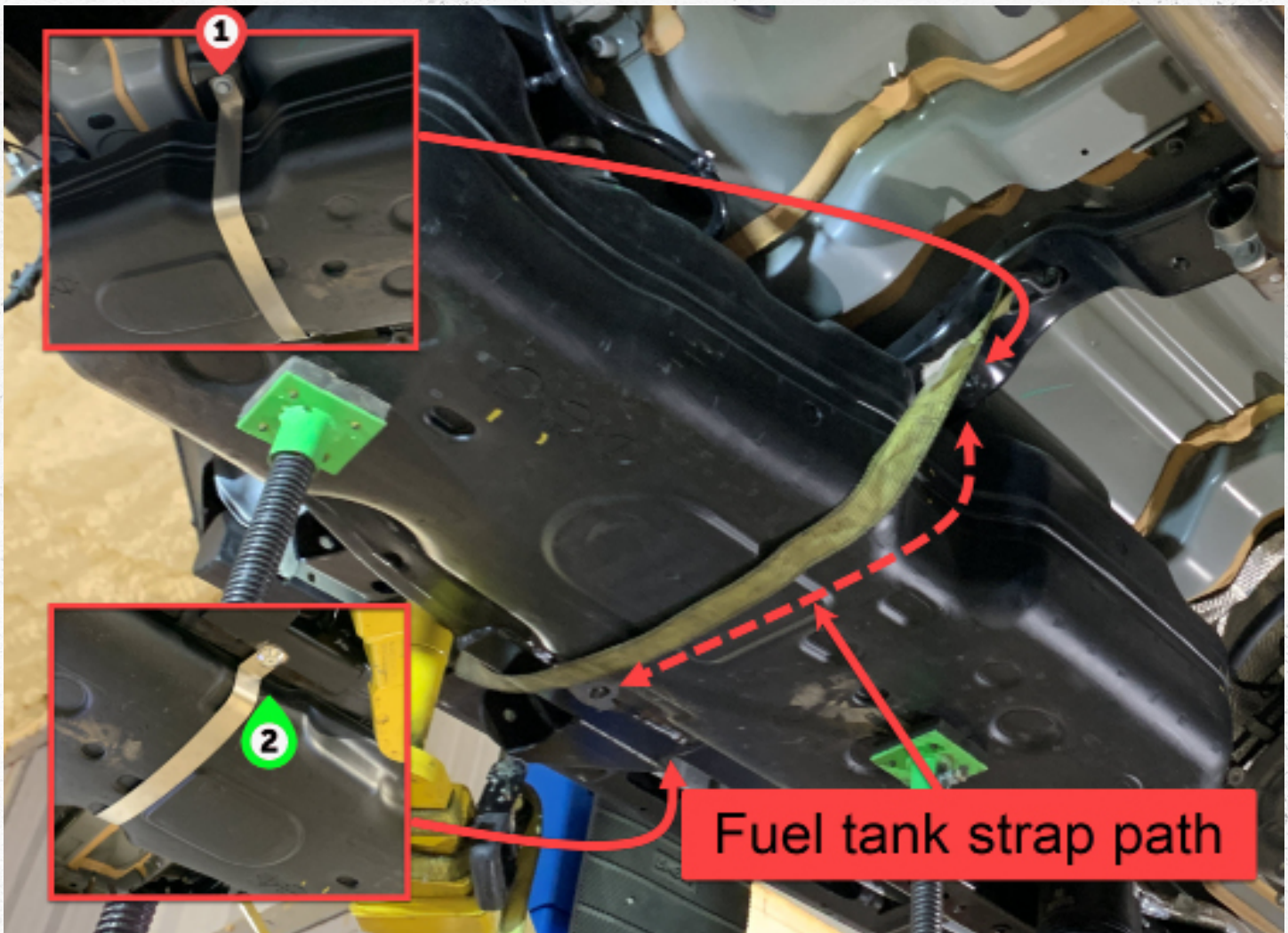

Step 5: Once the factory fuel tank skid has been removed, install the fuel tank strap by installing 1 - OEM 12mm bolt **1** with a 18mm socket AND 1 - 12mm x 40mm counter sink bolt & counter sink washer **2** using the 7/32 Allen wrench. The fuel tank strap hardware can be tightened at this stage. Once the fuel tank strap is mounted you can remove the ratchet strap.

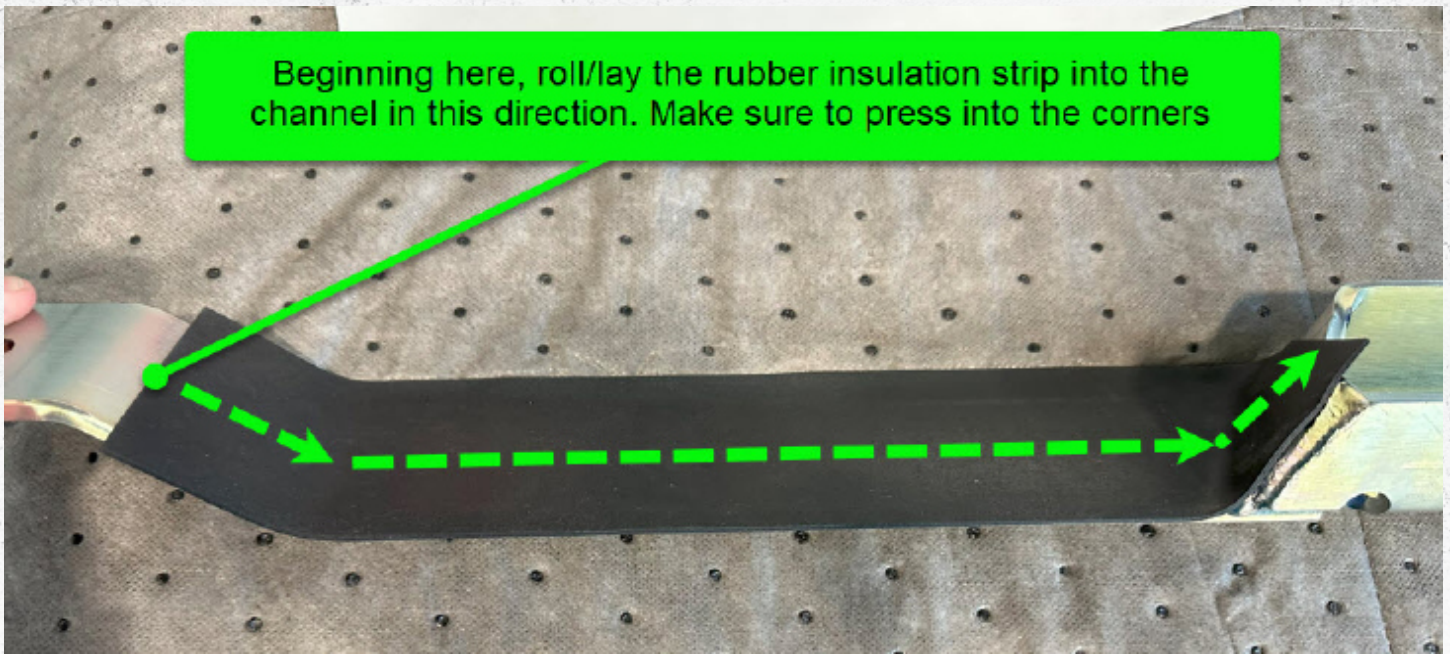

Step 6. Remove the adhesive backing strip from the rubber insulation and attach it as seen above. Make sure to lay it on squarely and press it into the corners.



Step 7. Loosely install the provided cross member using 1- M12 x 40 flathead bolt with the tapered washer 1 as shown below.

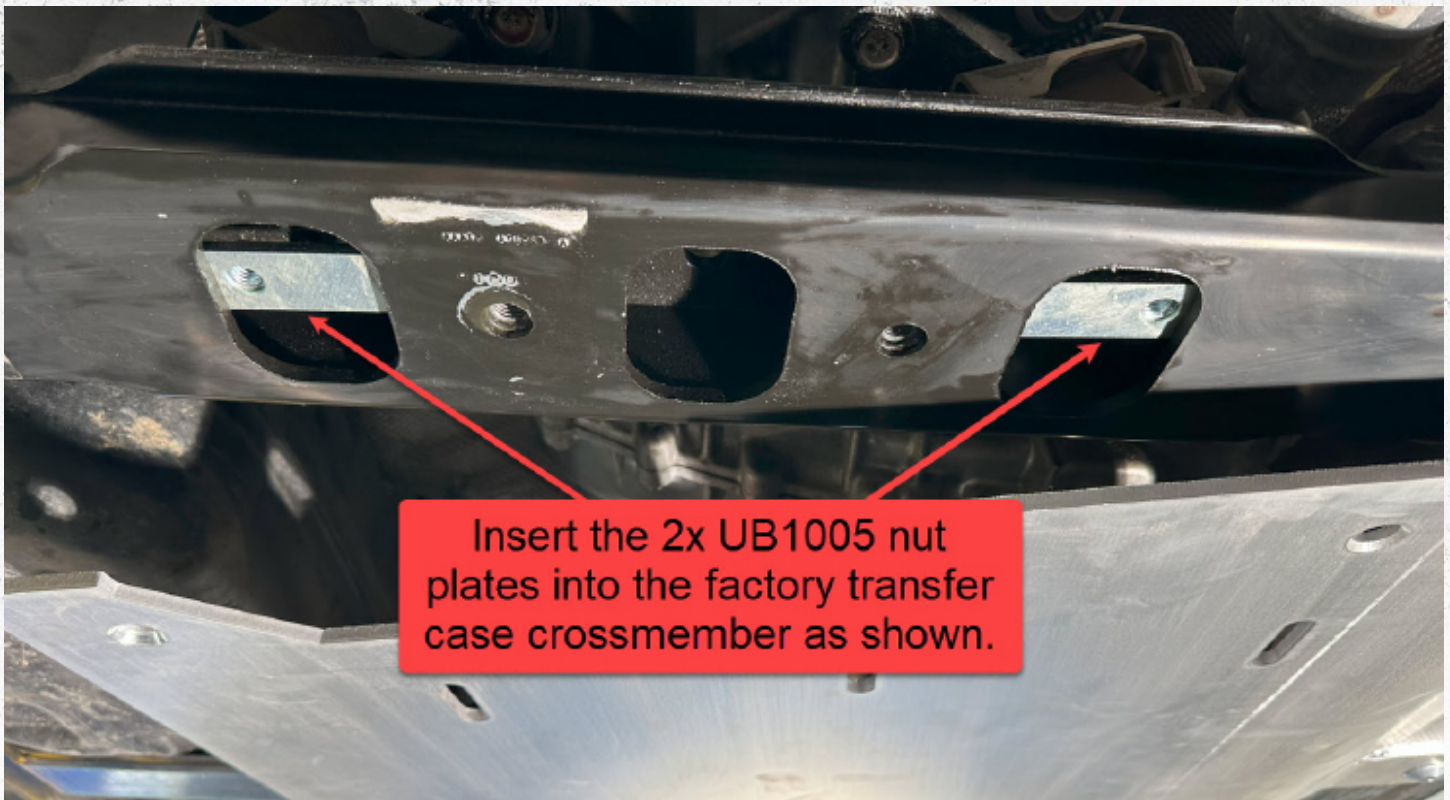

Step 8. Insert the 2 nut plates as shown above.

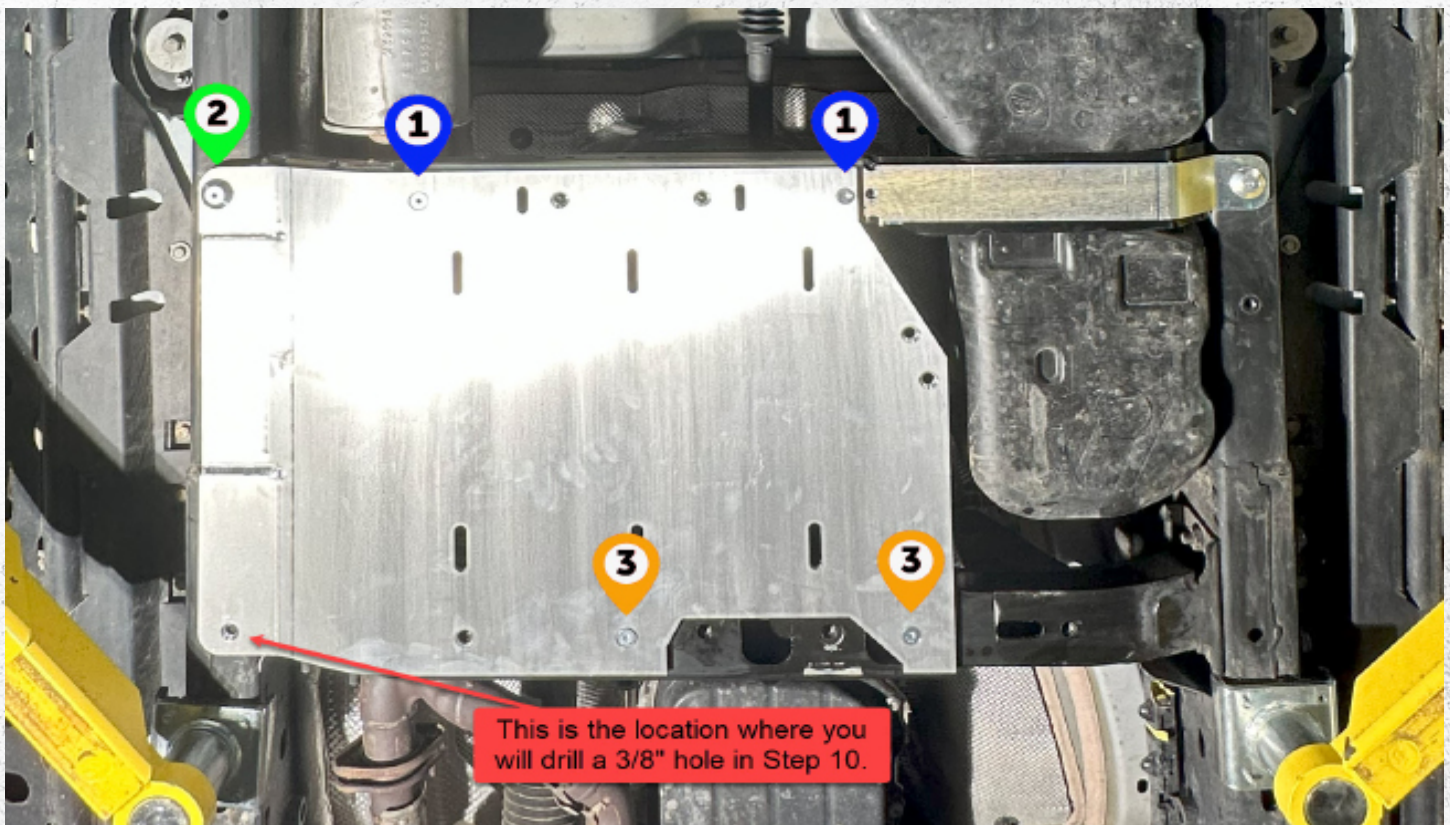

Step 9. Loosely secure the T-case skid onto the support cross member and factory cross member using 2 - 3/8 x 1" flat head bolts 1, 2 - 3/8 x 1.5" 3 and 1 - M12 X 40mm bolts with the tapered washer 2 using the 7/32 Allen wrench. In the next step you will drill a hole in the frame marked by the (RED) arrow. Once all of this hardware is installed, go ahead and tighten it starting from the back of the vehicle moving forward.

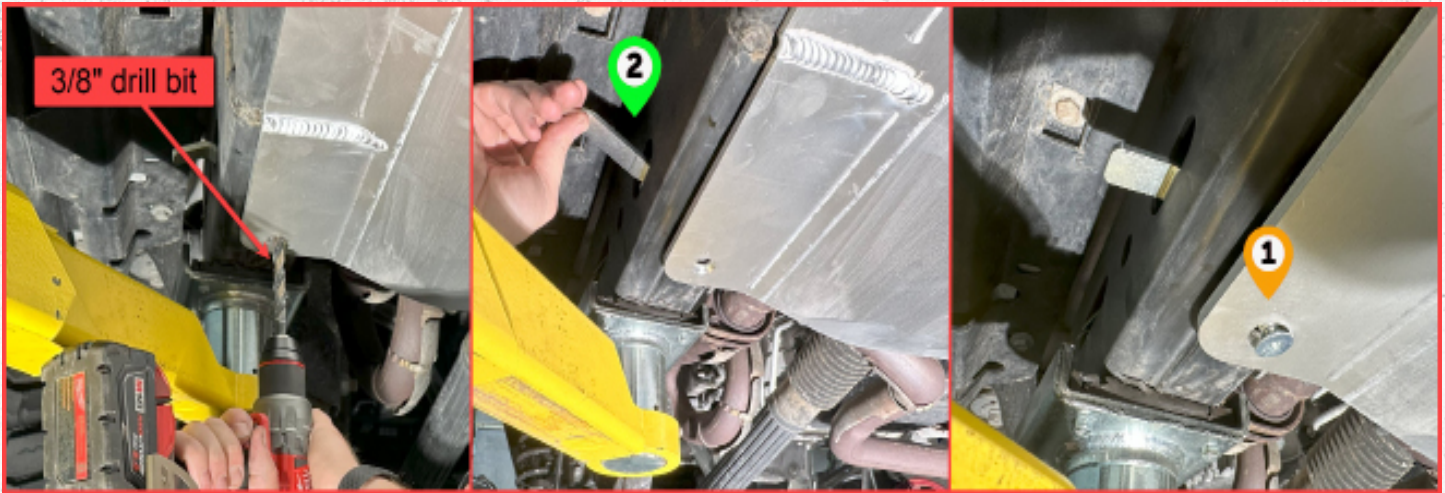

Step 10. Once the skid plate hardware is tight, drill a 3/8" hole in the location shown.  
 NOTE: Using a smaller bit to first drill a pilot hole will help.

Step 11. Insert UB1002 3/8" driver side nut plate **2** into the frame as shown and loosely install 1 - 3/8 x 1.5" flat head bolt **1** with a 7/32 allen wrench. Now loosen all of the transfer case skid hardware.

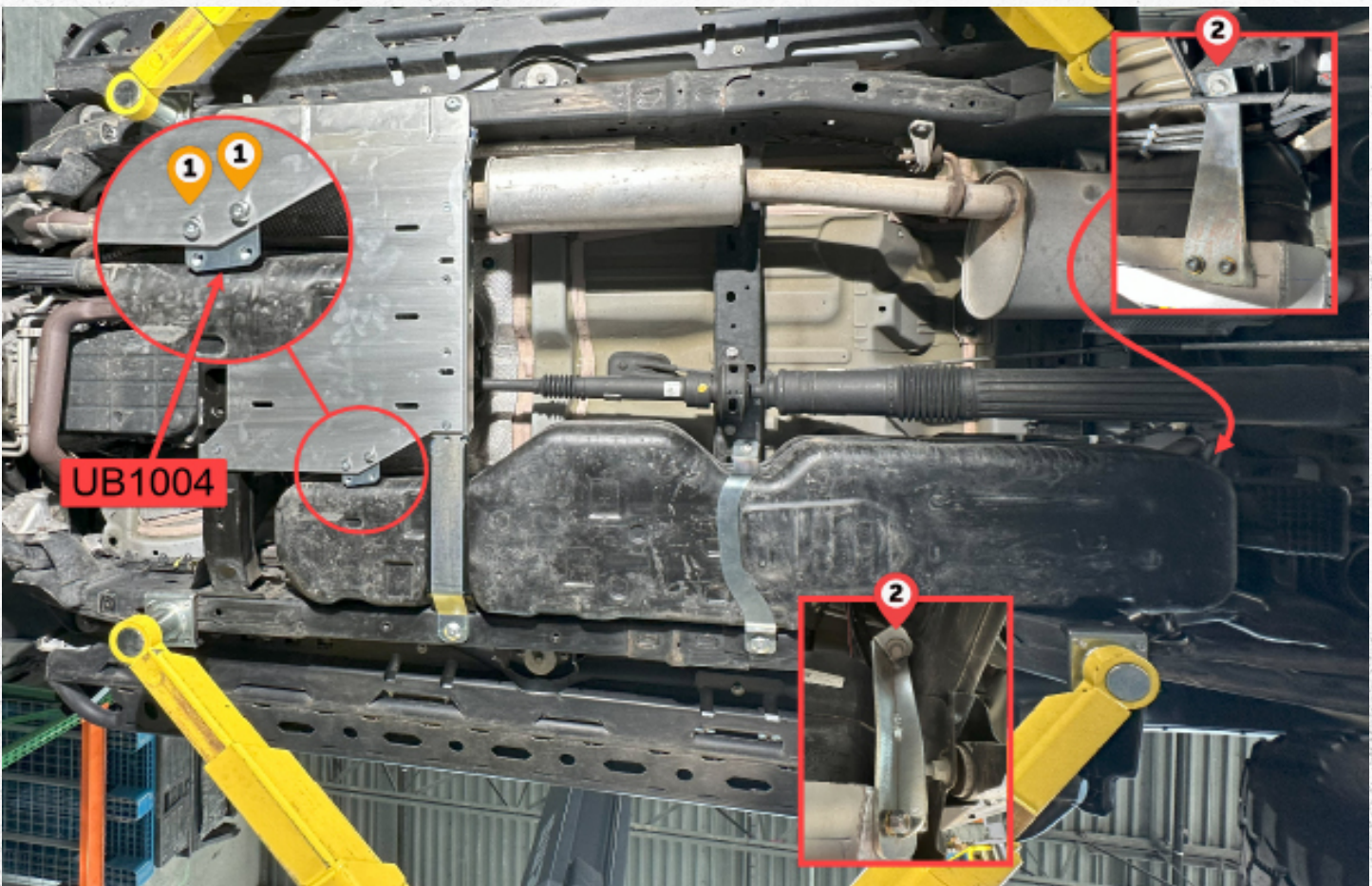

Step 12. Loosely install fuel tank inner JT4150-14 and outer JT4150-13 support brackets using 2 - OEM 12mm bolts **2** (removed from original skid) with a 18mm socket. With 2 - 3/8 x 1" flat head bolts **1** loosely install UB1004 using a 7/32 allen wrench

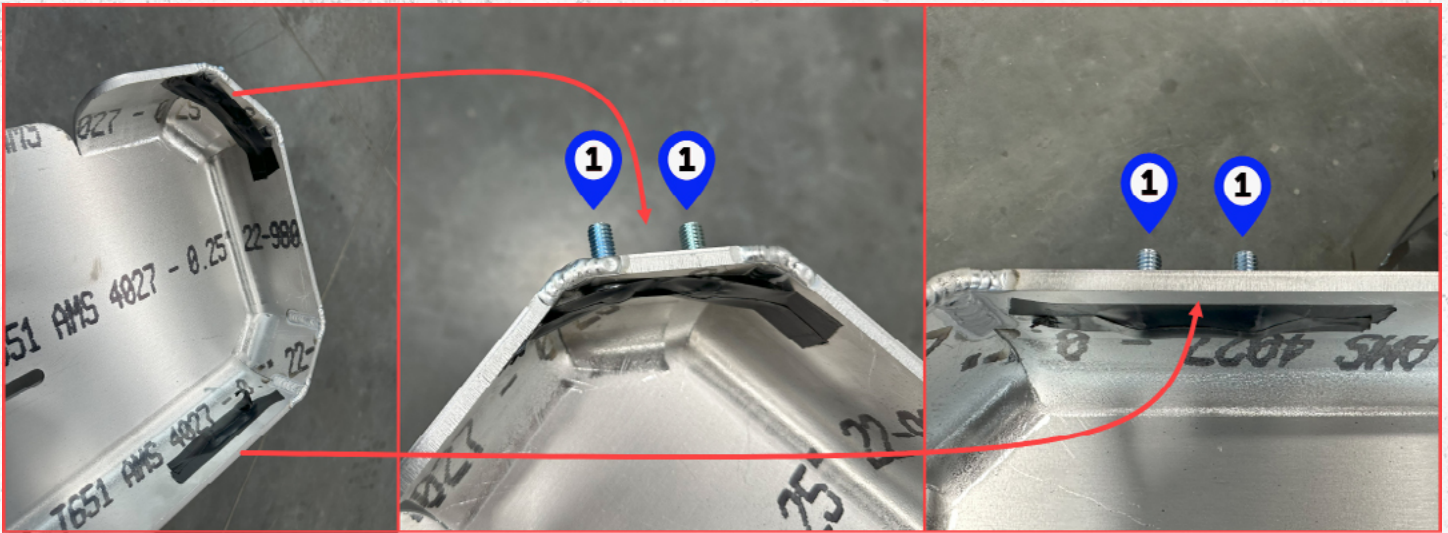

Step 13. Using tape secure 4 - 3/8" x 1" carriage bolts 1 to the fuel tank skid prior to installing the fuel tank skid onto frame and support cross member. Electrical tape works well.

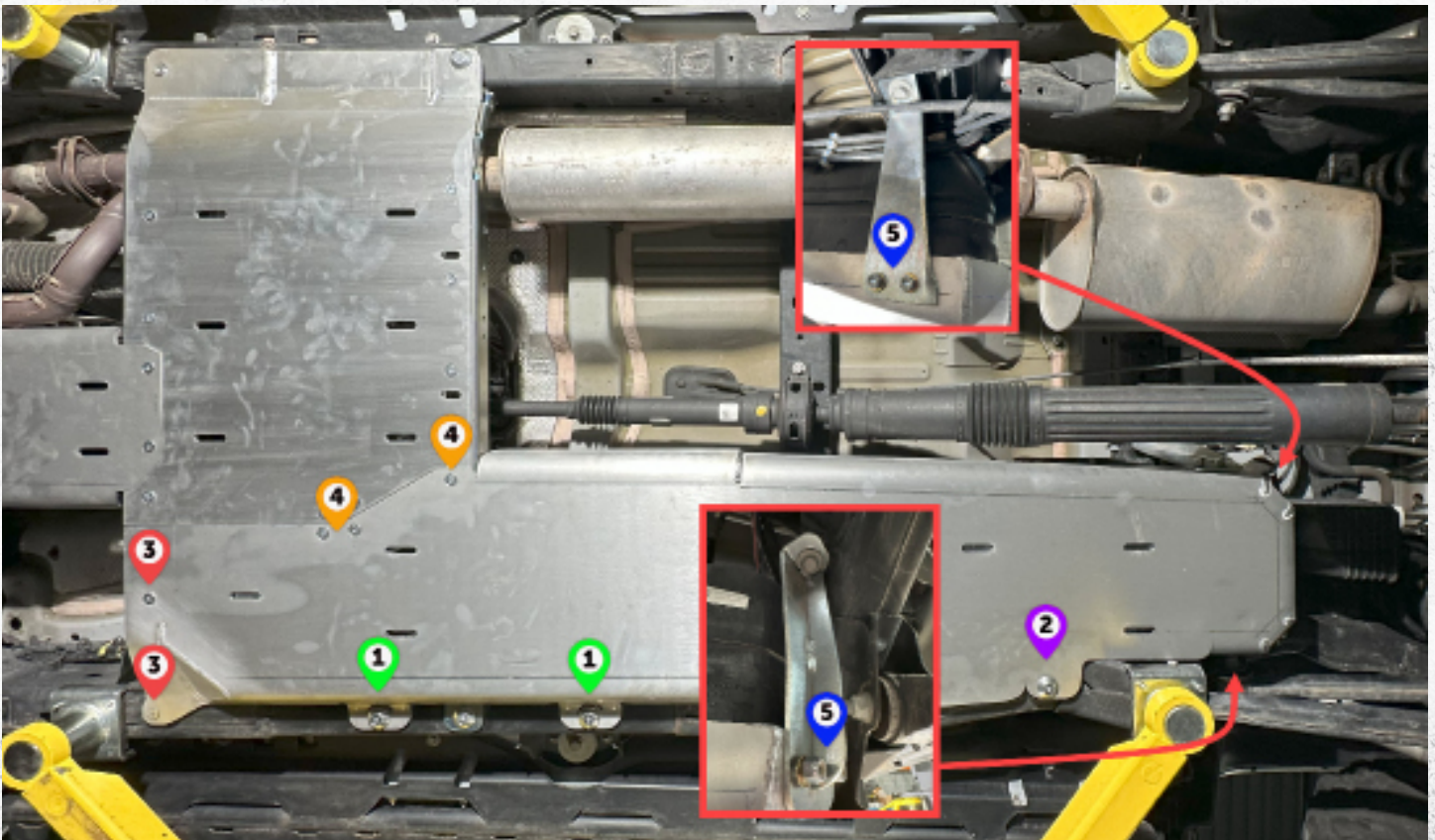

Step 14. Using the 7/32 Allen wrench loosely assemble the gas tank skid with 4 3 - 3/8 x 1" flathead bolt, 1 3 - M12 x 40mm flathead bolts with tapered washers AND 3 2 - M12 x 40mm flathead bolt. Assemble the fuel tank skid to the fuel tank skid brackets using 5 4 - 3/8 nylock nuts with 4 3/8 zinc plated washers using a 9/16 socket or wrench.

At location 2 place the supplied machined aluminum spacer between the skid and the frame when installing the custom M12 x 40mm flat head bolt and tapered washer.

NOTE: you may need to use a jack to push the skid up at the 2 location.

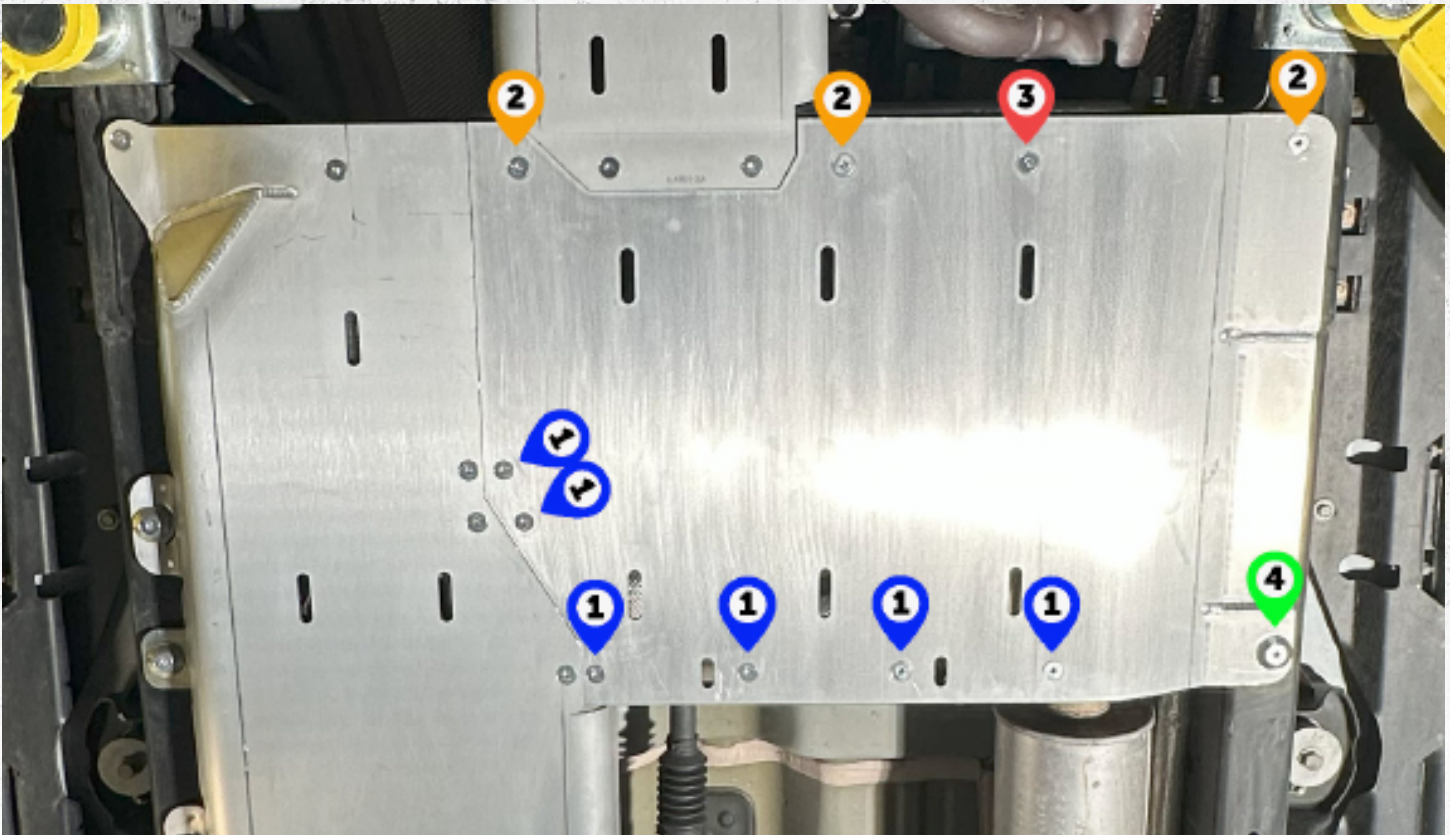

Step 15. Loosely install the balance of the transfer case hardware as shown above. Verify hardware is as follows: 3 - 3/8 x 1.5" flat head bolts 2. 6 - 3/8 x 1" flat head bolts 1. 1 - M12 x 40 custom flat head bolt 3. 1 - M12 x 40 custom flat head bolt with machined tapered washer 4.

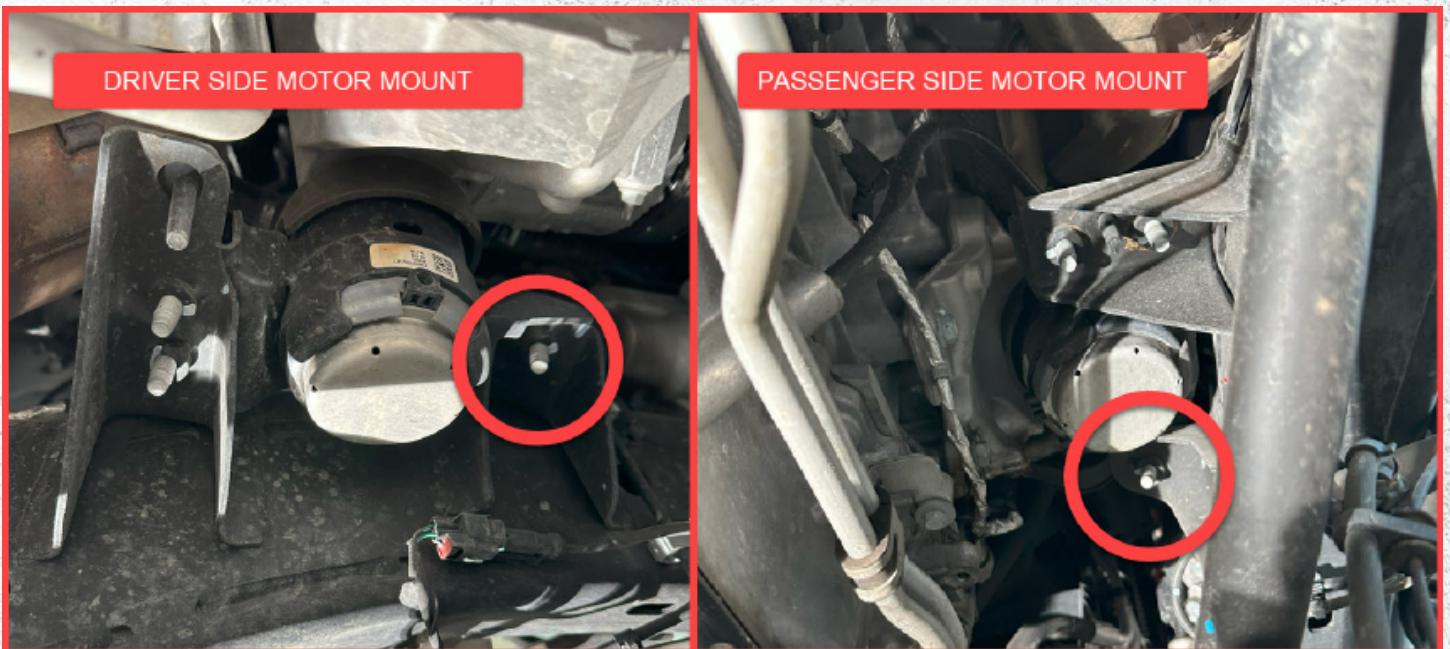

Step 16. To install the motor mount skid brackets, first remove the factory 10mm bolts from these two locations (RED). Keep the Driver side OEM hardware.



**DRIVER SIDE MOTOR MOUNT BRACKET JT4150-5A. THE BRACKET IS INSTALLED ON TOP OF THE MOTOR MOUNT.**

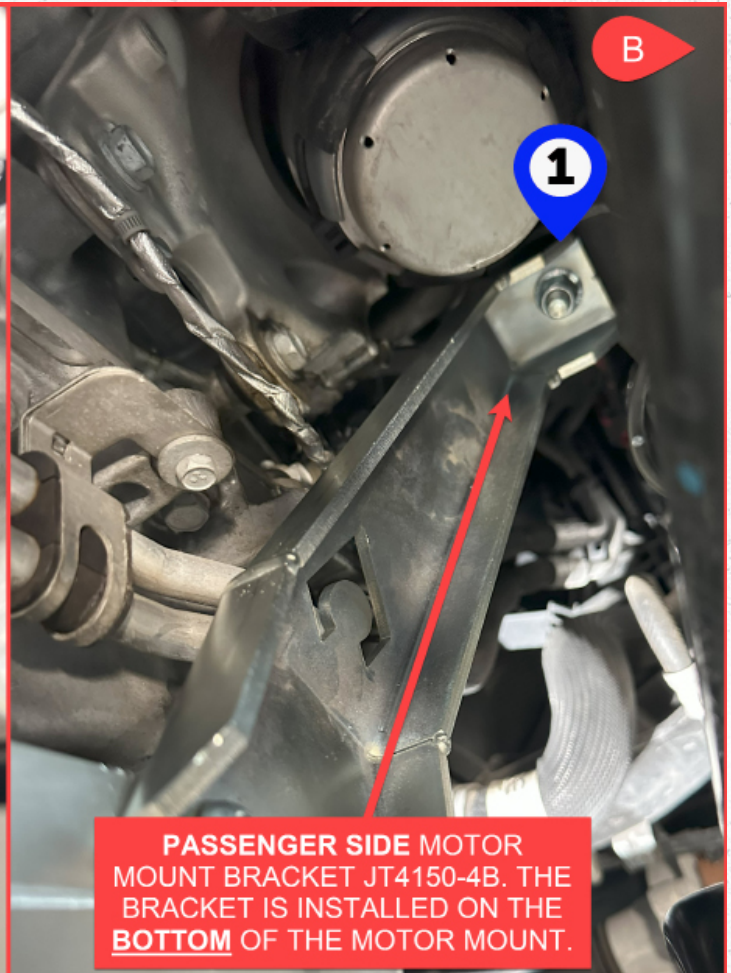

**PASSENGER SIDE MOTOR MOUNT BRACKET JT4150-4B. THE BRACKET IS INSTALLED ON THE BOTTOM OF THE MOTOR MOUNT.**

Step 17.

A: Loosely install the DRIVER SIDE motor mount bracket JT4150-5A on TOP of the motor mount using 1 - M10 OEM motor mount bolt 2 with a 13mm wrench/socket.

B: Install 1 - M10 x 40mm bolt and zinc washer 1 into the PASSENGER SIDE motor mount location using a 17mm socket. Tighten this hardware. Loosely install the PASSENGER SIDE bracket JT4150-4B on the BOTTOM of the motor mount using 1 - M10 flange nut 1 with a 15mm socket.

**NOTE: recommend applying blue Loctite to the threads of the M10 bolts before installing them into the motor mounts**

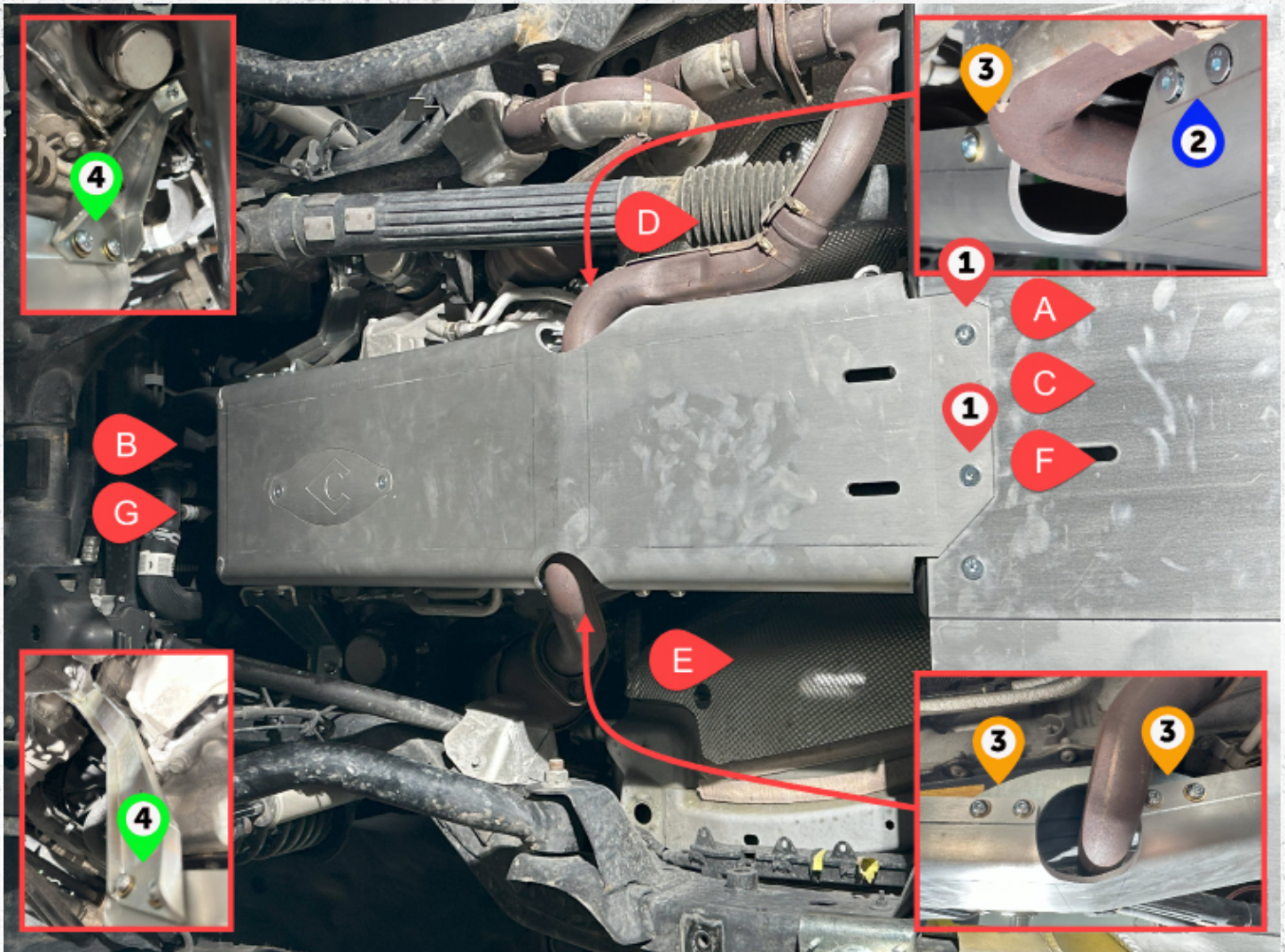

Step 18. FOR SMOOTHEST INSTALLATION FOLLOW THESE STEPS, IN THE ORDER INSTRUCTED.

- A. Loosely install the engine skid starting at the cross member using 2 – M12 x 40mm custom flat-head bolts **1** with the 7/32 allen wrench.
- B. Loosely install 1 x the following: 3/8 x 1” button head bolts, 2 - yellow zinc washers and 1 - 3/8 nylock nut **4** into each motor mount bracket by hand.
- C. Remove the 2 – M12 x 40mm custom flat head bolts **1** from the cross member to allow the engine skid to hang loosely.
- D. Install and tighten first the 2 - 3/8 x 1” flat head bolts **2** and then the 2 - 3/8 x 3/4” button heads bolts **3** using a 7/32 allen wrench. NOTE: use the ball end 7/32 allen wrench here
- E. Install and tighten the 4 - 3/8 x 3/4” button heads bolts **3** with a 7/32 allen wrench.
- F. Loosely reinstall the 2 – M12 x 40mm custom flathead bolts **1** using the 7/32 allen wrench.
- G. Loosely install the remaining 2 x 3/8 x 1” button head bolts, 2 - yellow zinc washers and 1 - 3/8 nylock nut **4** into each motor bracket with the 7/32 allen wrench and 9/16 inch wrench.

**Verify ALL hardware is loosely installed unless otherwise stated**

## JT4155 INSTALLATION INSTRUCTIONS

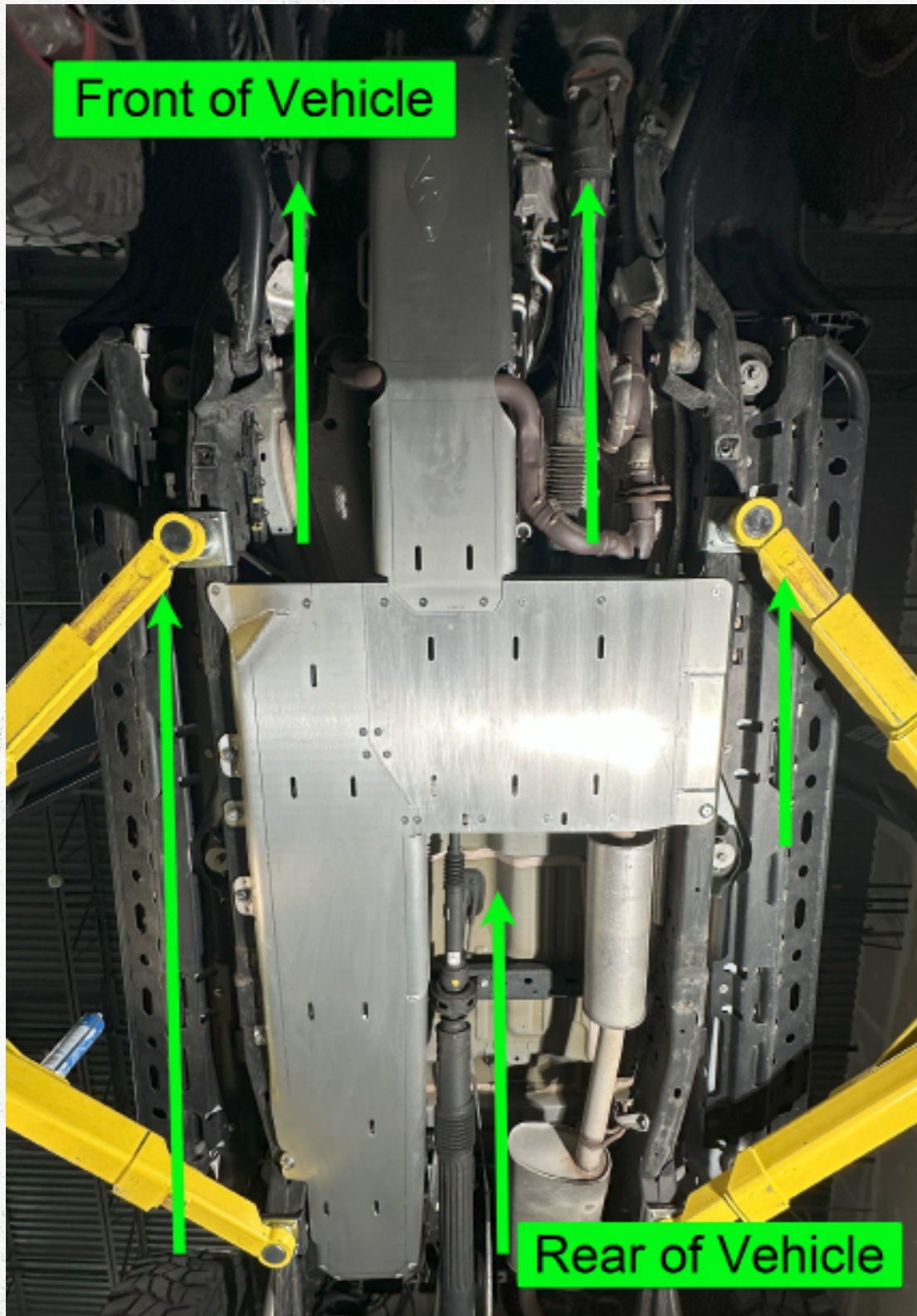

Step 19. Starting from the rear of the vehicle while working your way forward to the front, tighten/torque all skid and bracket hardware that was previously loosely installed on fuel tank skid, T-case skid, and engine oil skid.

## CONCLUSION AND MAINTENANCE GUIDE



### CONCLUSION

Congratulations on finishing the installation for your Artec Industries Alpha Series Aluminum Belly pan.

Before driving your vehicle, inspect all bolts again to ensure proper tightness.

If you used a vehicle lift, take proper care to ensure you lower your vehicle safely.

Now take your vehicle out and enjoy the outdoors in confidence.

### MAINTENANCE / CARE

- After 500 miles, inspect all components and hardware to ensure they are properly fastened.
- If driving during the winter where salt is used on the roads, thoroughly and frequently wash underside of vehicle to prevent salt based corrosion.
- If removal of skid panels is required for vehicle maintenance, and bolts will not loosen, tap the bolt heads with a small sledge hammer using moderate force. This will allow the threads to loosen.
- Spray wax or similar products can be used to create a protective barrier on raw metals to protect against long term corrosion.