

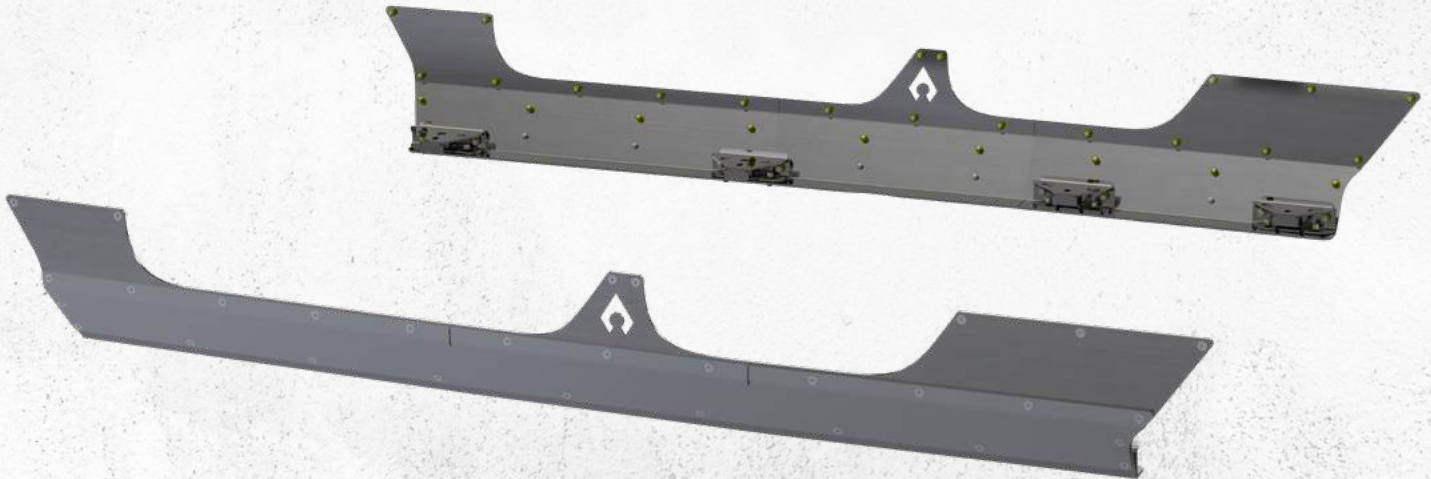

## **JT0401**

### **JT BOATSIDE ROCKER ARMOR KIT**



#### **ESTIMATED INSTALLATION TIME**

**6-8 hours**

#### **REQUIRED SKILLS**

- General Mechanics Skills

#### **REQUIRED TOOLS & SUPPLIES**

- Drill
- 1/8 drill bit
- 1/2 drill bit
- 17/32 drill bit
- Center punch
- 2-4 rolls of painters tape
- 2-5 clamps
- Press nut tool
- 10mm
- 13mm
- Ratchet
- 1/4 hex bit
- 5/32 hex bit
- T47 Torx bit
- T45 Torx bit
- Hammer
- Floor jack

#### **NOTES:**

- Component appearance in instructions may vary from those received

## WARNING MESSAGES

This product demands a basic understanding of mechanical procedures and should only be installed by individuals proficient with mechanic's tools. Any tasks involving welding or cutting parts should be performed by trained professionals. Artec Industries disclaims responsibility for mishaps arising from improper installation, or any damage or accidents resulting from cutting or welding tasks. Exercise caution and seek professional help as required.

## SAFETY

1. We've furnished a written installation guide, along with relevant details, to aid you in making safety-conscious decisions.
2. While these guidelines will highlight potential risks, it's crucial to exercise your personal judgment when performing any required steps.
3. Before initiating any tasks, it's essential to conduct a job safety analysis to identify specific hazards in your situation and take measures to eliminate or protect against them.
4. Before commencing the installation of this product, make sure you familiarize yourself with and fully understand all safety warnings and guidelines.

## DISCLAIMERS

All Artec Industries products should be installed by a competent, certified individual following the intended installation instructions for each product. Incorrect installations not only nullify any warranties but could also lead to product damage or even damage to the vehicle it's installed on. Prior to installation, carefully read all provided instructions or manuals, and watch any associated videos. For any doubts or queries, reach out to Artec Industries before beginning the installation process.

Many products necessitate lifting and supporting the vehicle off the ground. It is the installer's responsibility to ensure this can be done safely and that the right equipment is at hand to carry out the installation. Artec Industries installation instructions presume the installer is competent to lift the vehicle safely and correctly.

Modified vehicles won't perform identically to their stock counterparts. It's incumbent upon the vehicle owner to understand the alterations such modifications will bring to the vehicle's driving dynamics. These might encompass (but aren't limited to): changes in handling, braking, rollover angle, and potential incompatibilities with the factory-installed anti-lock braking systems, stability control systems, or traction control systems.

## SPECIAL NOTES

- Unless otherwise noted, all hardware should be **LOOSELY** tightened by hand until the very end of installation when all components are attached.

## JT0401 PARTS BILL OF MATERIALS

Please confirm you have all the listed parts below **BEFORE** beginning your installation. If any parts are damaged or missing, **KEEP ALL ORIGINAL BOXES and PACKAGING** and contact us.

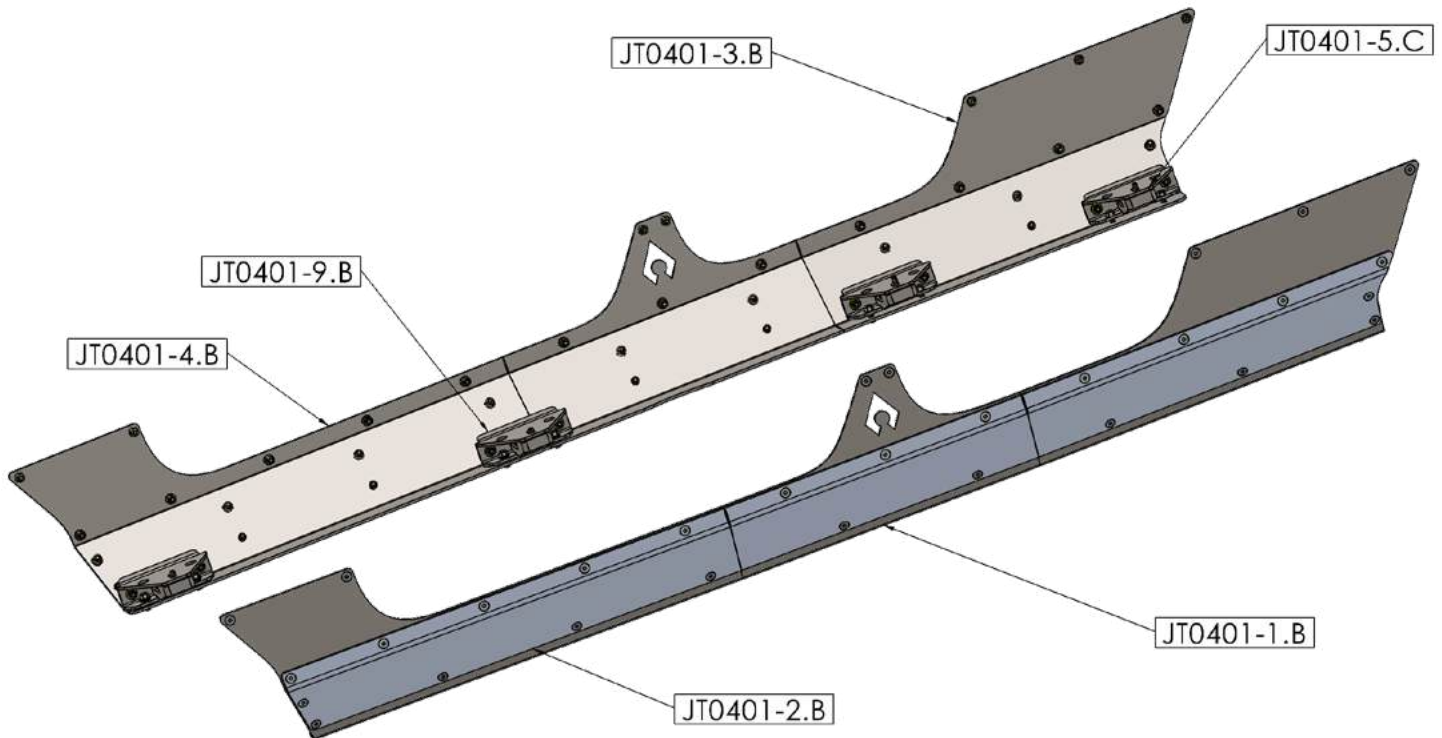

**NOTE:** The part numbers indicated above end in a "." and "letter" which indicate the revision number for the part. The etched part number on your physical parts do not need to match the above drawing revision exactly.

## JT0401 BILL OF MATERIALS

**NOTE:** The hardware BOM is specific to the kit and accessories placed in the order.

| ITEM NO. | DESCRIPTION  | QTY. |
|----------|--|------|
| A        | 5/16" Zinc-Plated Steel Washer   | 48   |
| A        | 5/16"-18 x 1.00" L Steel Button Head Bolt, Black Zinc                            | 16   |
| B        | 5/16-18 NYLON INSERT HEX LOCK NUT ZINC   | 32   |
| C        | 5/16-18 X 1 1/4in GRADE 5 CARRIAGE BOLT ZINC                                     | 16   |
| D        | 5/16 -18 x .75in Counter Sink Allen Head Bolt - MAGNI 565 COATING                | 46   |
| E        | 5/16-18 Zinc-Plated Steel Heavy-Duty Rivet Nut                                   | 56   |
| F        | 5/16"-18 x 1" Long Steel Flat Socket Head Screw Clear Zinc                       | 28   |
| A        | M8-1.25x25mm Steel Flanged Hex Head Bolt - MAGNI 565 COATING                     | 8    |
| B        | Zinc-Plated Steel USS Washer, Grade 5, for 1/4" Screw Size, 0.313" ID, 0.750" OD | 8    |

## ASSEMBLY INSTRUCTIONAL GUIDE



### Step 1: (A)

If your vehicle is equipped with factory rock rails/ sliders. Remove them using a 10mm and 13mm socket. There are four brackets per side holding the factory rock rails.



## ASSEMBLY INSTRUCTIONAL GUIDE



**Step 2:**  
For this installation we removed the doors for an unobstructed view of our installation process. The doors can be removed using a T47 and T45 bit with ratchet.



**Step 3:**

Tap the vehicle on each side starting from the middle of the lower door hinge moving to the bottom of the rocker panel.



**Step 4:**

Drill the eight factory holes using a 1/2" drill bit and repeat to the other side of the vehicle.

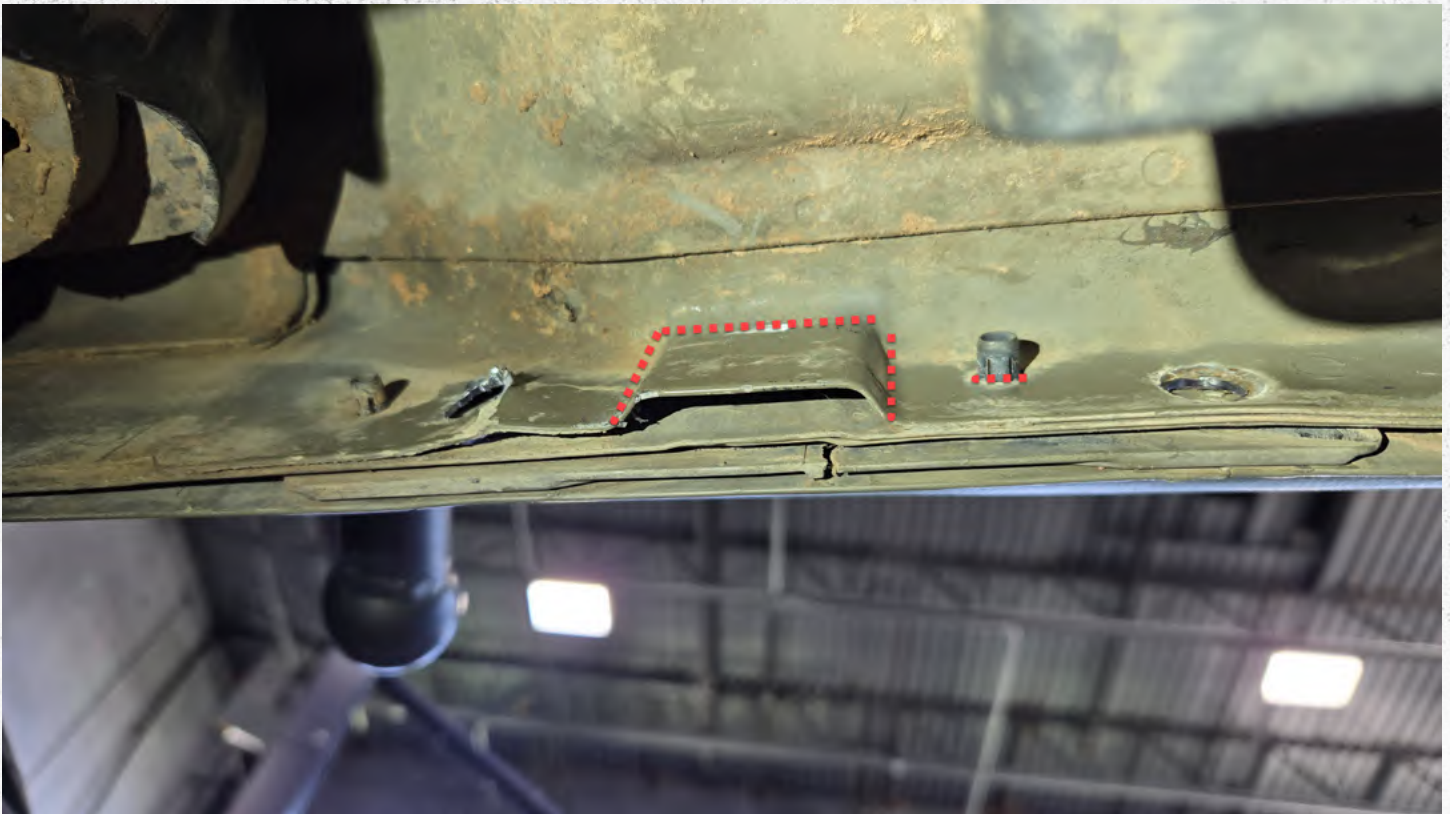

**Step 5:**

Image above shows the passenger front of the vehicle. Remove the “bubble” using a saw to bring it flush with the rocker pinch seam. Cut the plastic extrusion that is furthest from the front of the vehicle.



**Step 6:**

Grind the “bubble” flat so the new boat-side rocker mounts will sit flush to the seam.

**Repeat step 5 and 6 on the Driver side of the vehicle.**



**Step 7:**

Install the four base brackets to each side of the vehicle using the factory bolt. Install this bolt finger tight.



**Step 8:**

Install JT0401-11 with two 5/16" carriage bolts **RED C** through the pinch seam and into the bracket JT0401-5, secure it with two zinc plated washers and two nylon lock nuts.

**Two JT 0401-5-W goes in the rear of the vehicle on the driver and passenger side of the vehicle.**



**Additional view of Step 8:**



**Step 9:**

With help, raise the steel boat-sides into place using a jack and snugly clamp it into place.

**You should still be able to move the armor for the next step of alignment.**

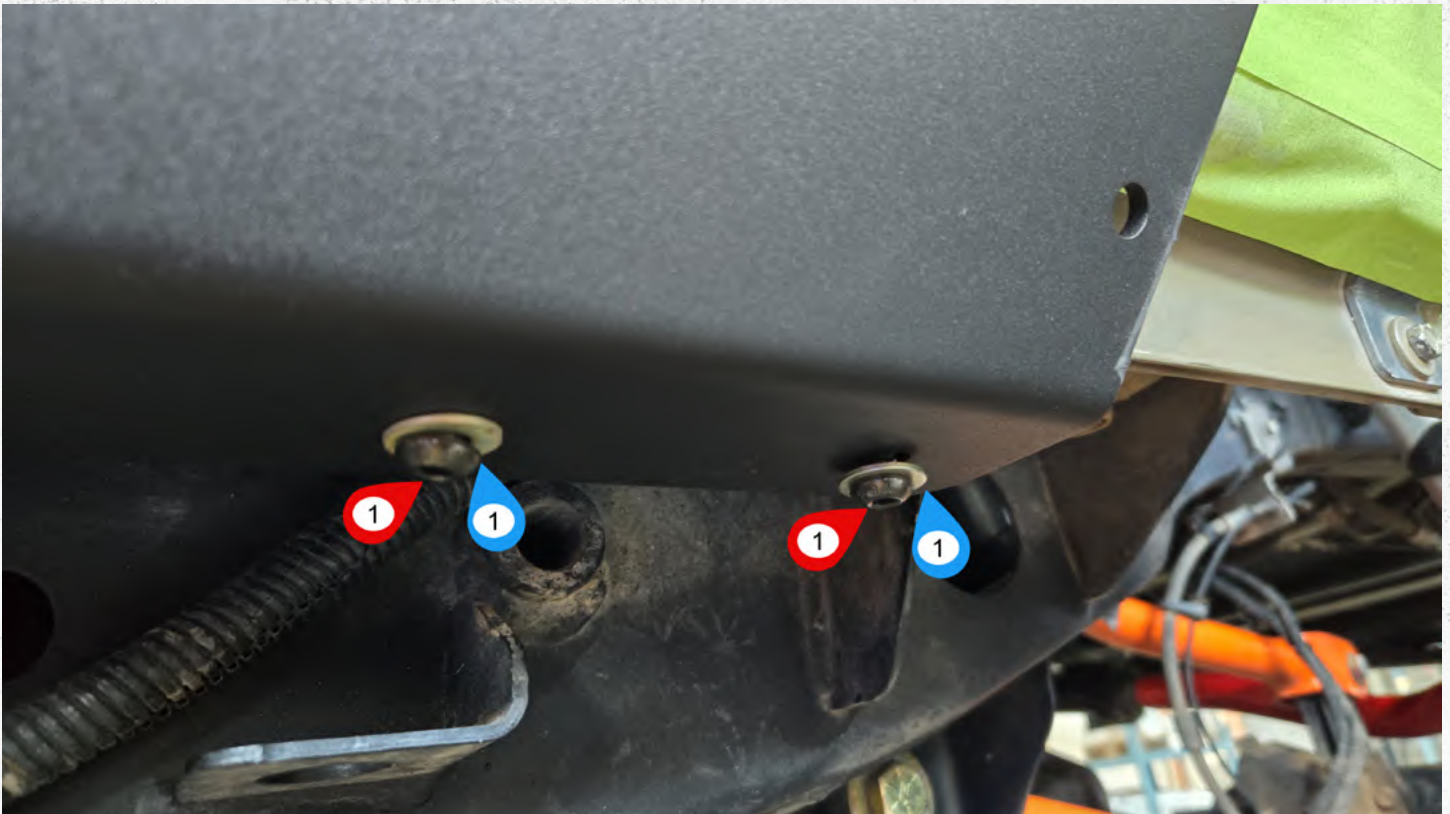

**Step 10:**

Install the eight 5/16" button head bolts with zinc washers and lock nuts.

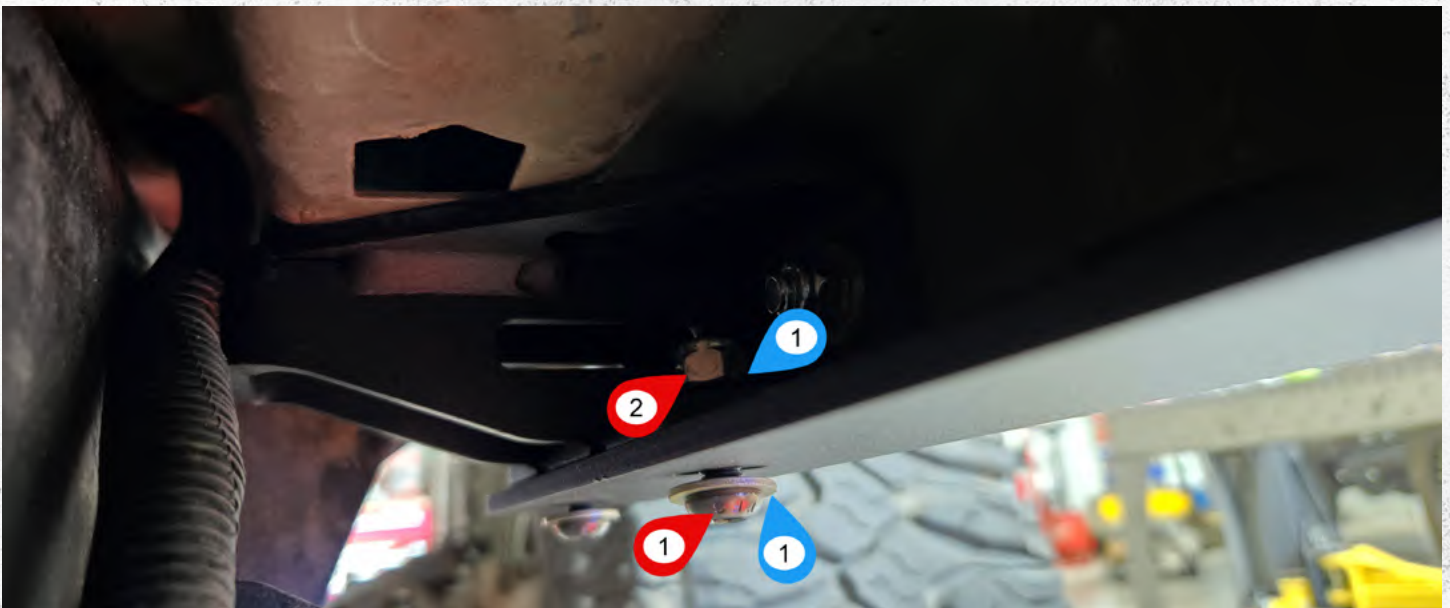

**Step 10:**

Additional view:

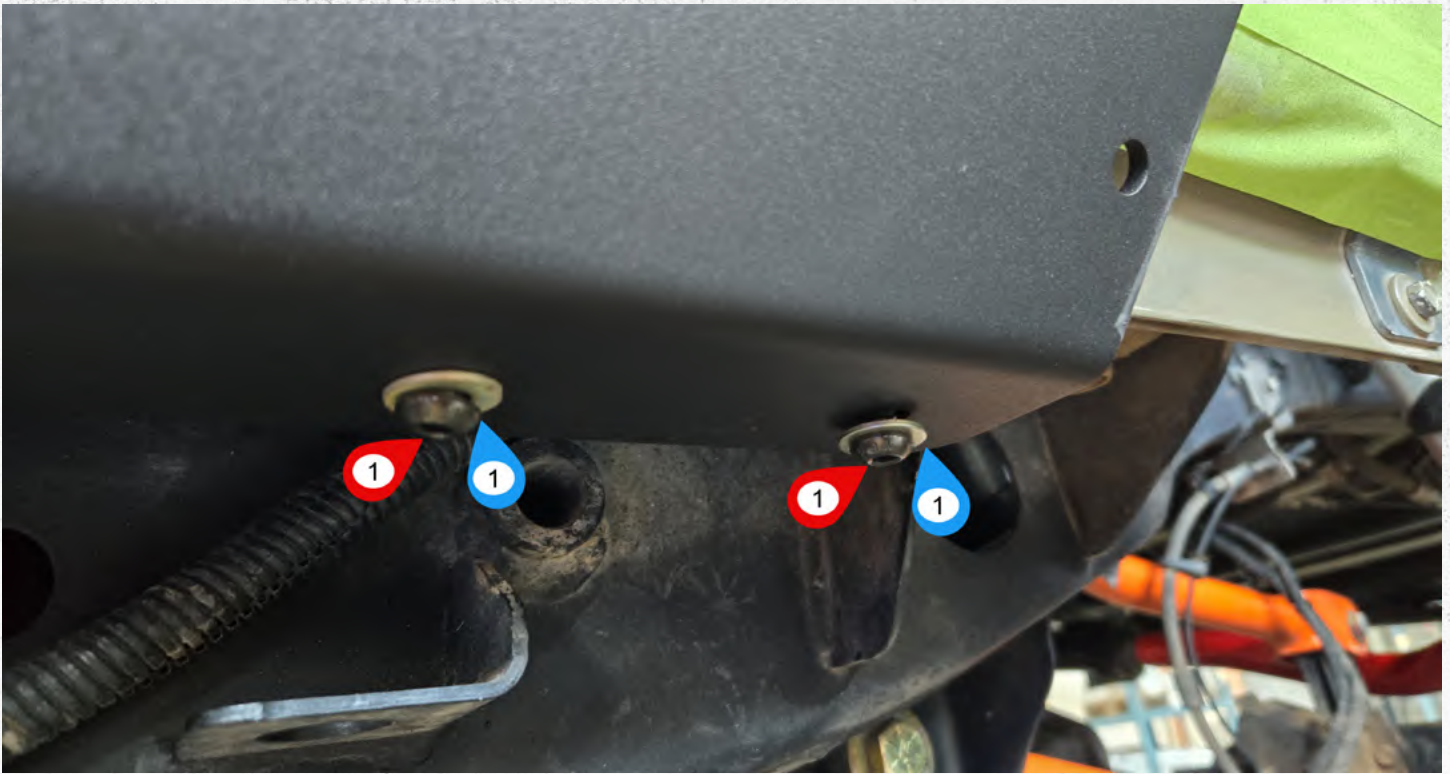

**Step 11:**  
Ensure that the 5/16" bolts are loose for best fitment results.



**Step 12:**  
Adjust the Boat-side armor until the center has equal gaps between the center pillar on the Jeep.

**Additional images on the next page of fitment.**

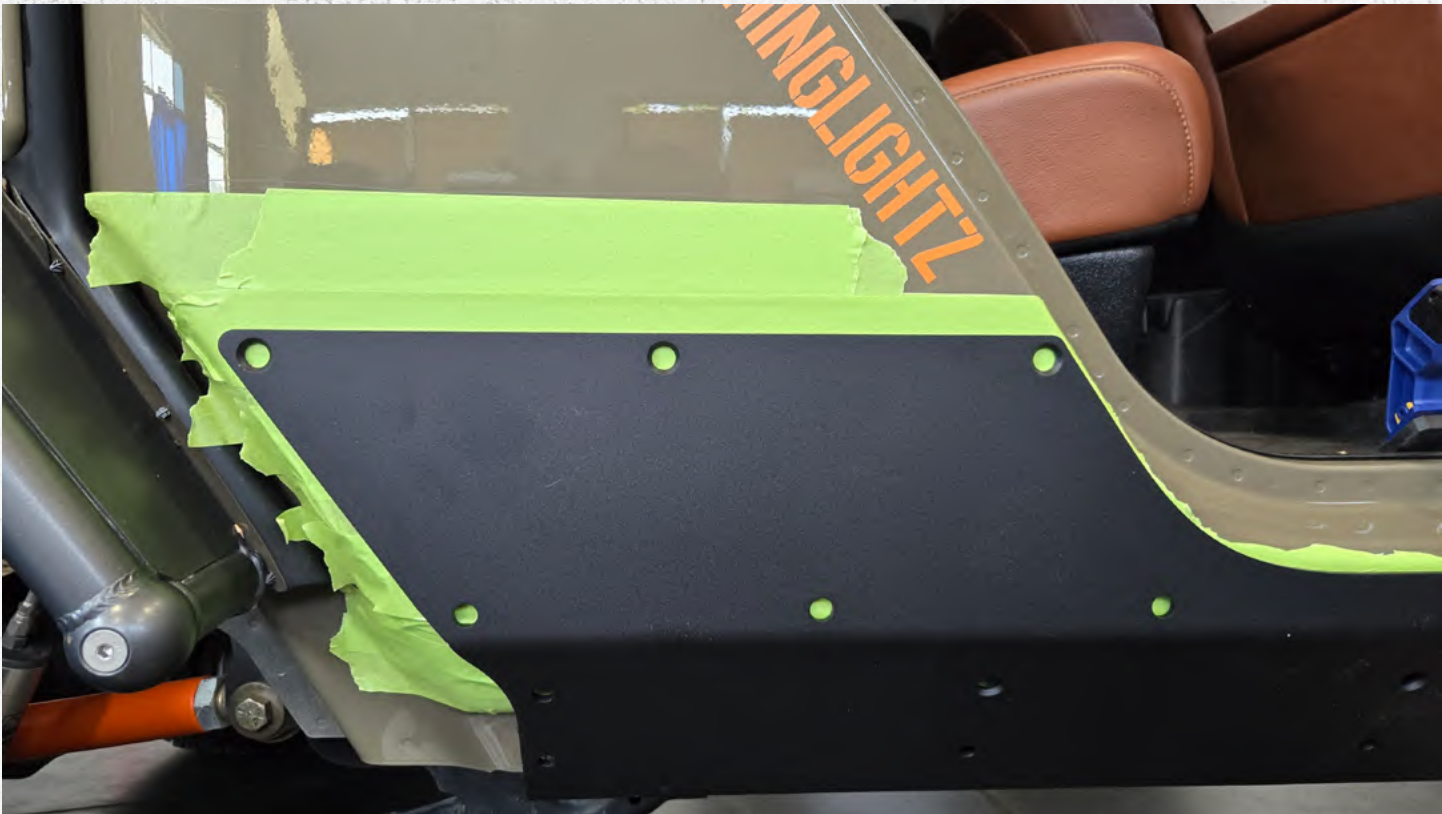

**Step 12: Additional views**



**Step 13: (A)**

For easiest installation, use a hammer with countersunk center-punch.

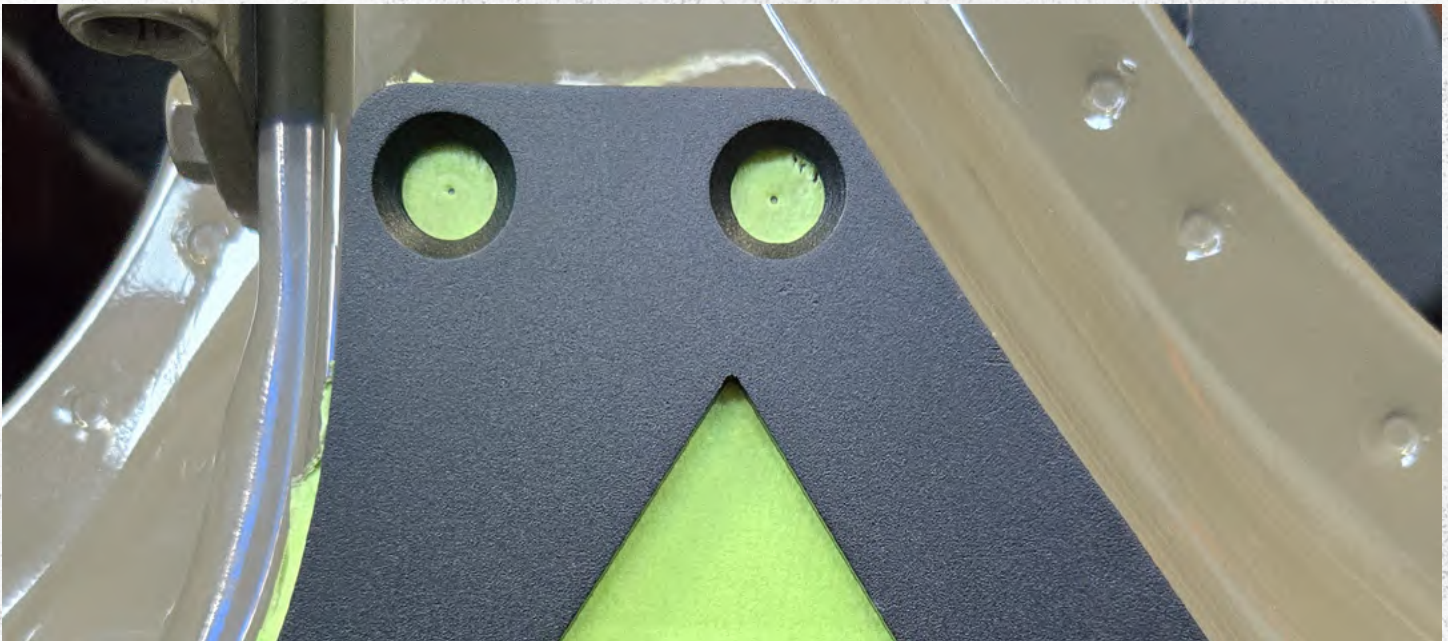

**Step 13: (B)**

Center-punch every hole on the rocker armor moving from the center of the vehicle outward.

**NOTE!!! Ensure that each mark is centered with the panel fully clamped into place, check that each mark is strong enough to drill after removing the rocker armor.**



**Additional view of step 13: (B)**



**Step 14**  
Remove the boat-side from the vehicle.



### Step 15

Drill all holes starting with a 1/8" drill bit moving up to the final 17/32" drill bit. **Take your time here.**

**Recommended to move two sizes up until the final drill bit size.**



### Step 16

Remove the tape after all holes have been drilled.



**Step 17: (Optional)**

We used a 10mm socket to loosen the driver and passenger front quarter panel to allow our press-nut tool to gain full range of motion.



**Step 18:**

Install the provided press-nuts into the drilled holes, there are 28 per side.

**NOTE!!! Set your press-nut tool ensuring it will have sufficient clamping onto one layer of sheet metal. There are portions of the vehicle with multiple layers! please adjust accordingly.**



**Step 19:**

For maintenance, coat each bolt in either ATF, penetrating oil, or other lubricants to prevent bolts from seizing.



**Step 20:**

Loosely install the fourteen 5/16" x .75" countersunk RED D hardware starting from the center of the vehicle, then move outward.

**We find that re clamping the boat-sides into place helps with installation of hardware.**



**Step 20: Additional view**



**Step 20: Additional view**

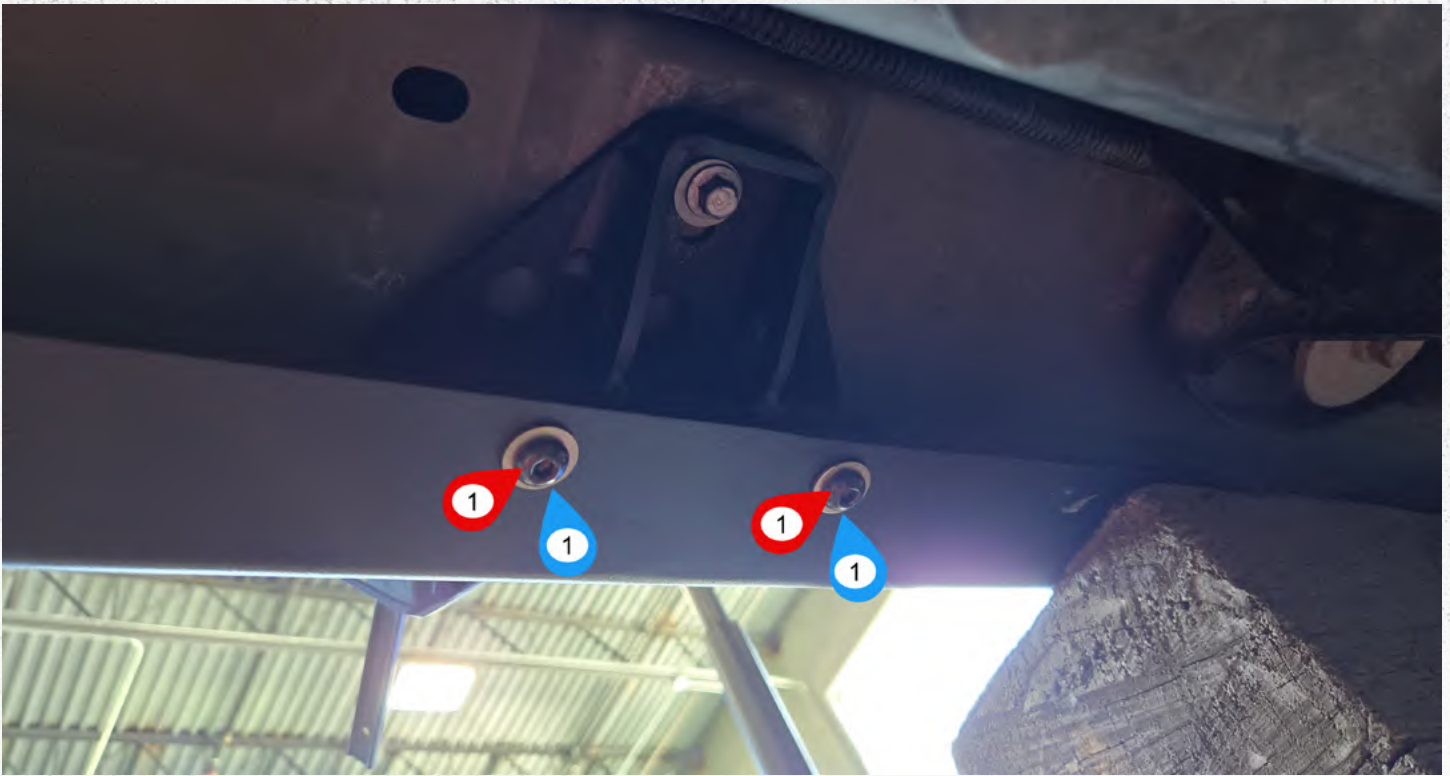

**Step 21:**

Install the two 5/16" button head bolts with four 5/16" zinc washers and two 5/16" nylon lock nuts to each bracket securing the boat side into place. **Tighten these last!!**

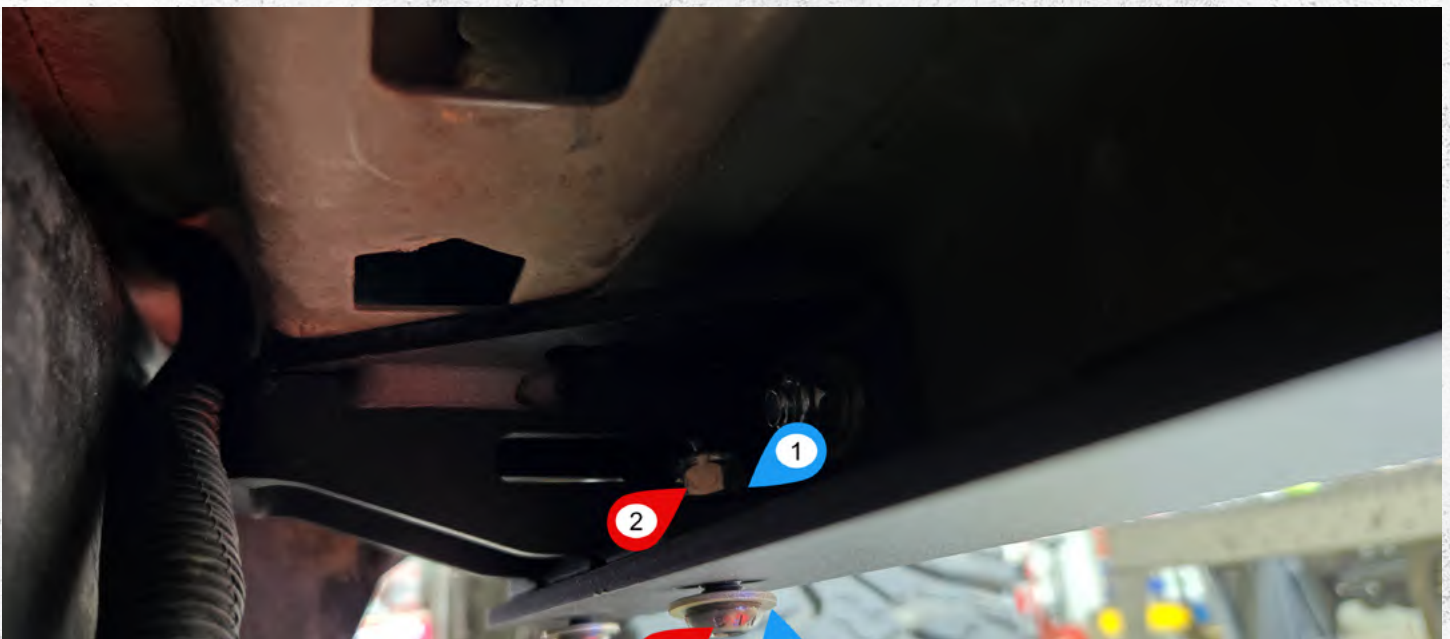

**Step 21: (Additional view)**



**Step 22:**

Moving again from the center of the vehicle outward, install the hardware as follows:

**RED D** 5/16" x .75" countersunk bolt (x9)

**RED F** 5/16" x 1" countersunk bolt (x14)

**Repeat on other side of the vehicle.**



**Step 23:**

Tighten all hardware moving from the center outwards.



## Verify ALL previously installed hardware is tight / torqued to specifications.

### CONCLUSION

Congratulations on finishing the installation for your Artec Industries JT boatside armor. Before driving your vehicle, inspect all bolts to ensure they are properly tightened.

If you used a vehicle lift, take proper care to ensure you lower your vehicle safely.

Now take your vehicle out and enjoy the outdoors in confidence.

### MAINTENANCE / CARE

- After 500 miles, inspect all components and hardware to ensure they are properly fastened.
- If driving during the winter where salt is used on the roads, thoroughly and frequently wash under-side of vehicle to prevent salt based corrosion.
- If removal of skid panels is required for vehicle maintenance, and bolts will not loosen, tap the bolt heads with a small sledge hammer using moderate force. This will allow the threads to loosen.
- Spray wax or similar products can be used to create a protective barrier on raw metals to protect against long term corrosion.