



## JL4127

### 4XE BELLYPAN SKID W/ POWER PACK AND EXHAUST SKID



#### ESTIMATED INSTALLATION TIME

**1 hours**

#### REQUIRED TOOLS & SUPPLIES

- 7/32 Hex Bit
- 5/32 Hex Bit
- 10mm Socket
- 13mm Socket
- 15mm Socket
- 18mm Socket
- Ruler
- Jack/ support
- Magnet pen/ stick

#### REQUIRED SKILLS

- General Mechanics Skills

#### NOTES:

- Component appearance in instructions may vary from those received
- Kit requires lowering of the fuel tank
- Electrical gloves should be worn when installing the powerpack skid.

## WARNING MESSAGES

This product demands a basic understanding of mechanical procedures and should only be installed by individuals proficient with mechanic's tools. Any tasks involving welding or cutting parts should be performed by trained professionals. Artec Industries disclaims responsibility for mishaps arising from improper installation, or any damage or accidents resulting from cutting or welding tasks. Exercise caution and seek professional help as required.

## SAFETY

1. We've furnished a written installation guide, along with relevant details, to aid you in making safety-conscious decisions.
2. While these guidelines will highlight potential risks, it's crucial to exercise your personal judgment when performing any required steps.
3. Before initiating any tasks, it's essential to conduct a job safety analysis to identify specific hazards in your situation and take measures to eliminate or protect against them.
4. Before commencing the installation of this product, make sure you familiarize yourself with and fully understand all safety warnings and guidelines.

## DISCLAIMERS

All Artec Industries products should be installed by a competent, certified individual following the intended installation instructions for each product. Incorrect installations not only nullify any warranties but could also lead to product damage or even damage to the vehicle it's installed on. Prior to installation, carefully read all provided instructions or manuals, and watch any associated videos. For any doubts or queries, reach out to Artec Industries before beginning the installation process.

Many products necessitate lifting and supporting the vehicle off the ground. It is the installer's responsibility to ensure this can be done safely and that the right equipment is at hand to carry out the installation. Artec Industries installation instructions presume the installer is competent to lift the vehicle safely and correctly.

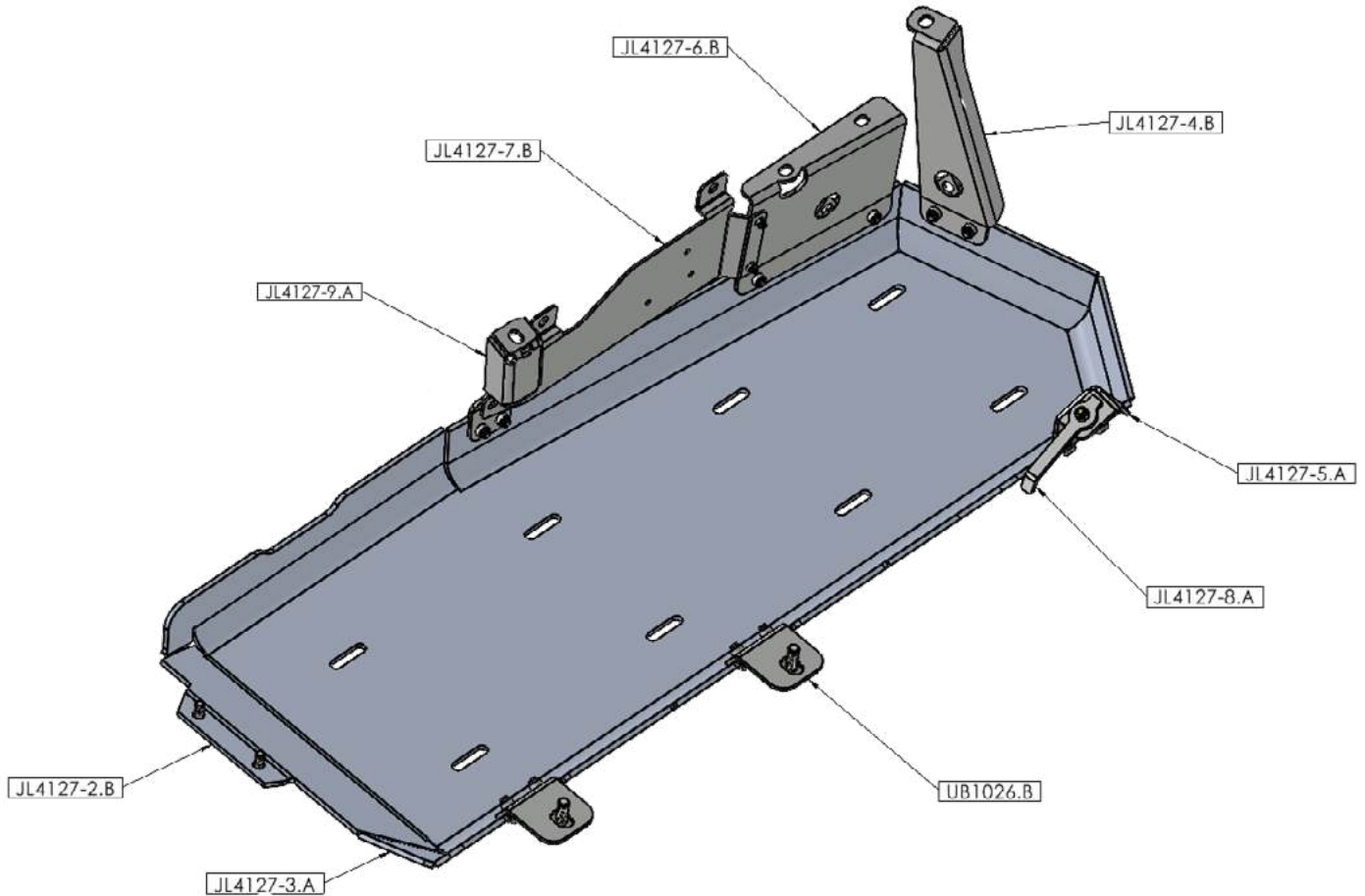
Modified vehicles won't perform identically to their stock counterparts. It's incumbent upon the vehicle owner to understand the alterations such modifications will bring to the vehicle's driving dynamics. These might encompass (but aren't limited to): changes in handling, braking, rollover angle, and potential incompatibilities with the factory-installed anti-lock braking systems, stability control systems, or traction control systems.

## SPECIAL NOTES

- Unless otherwise noted, all hardware should be **LOOSELY** tightened by hand until the very end of installation when all components are attached.

## JL4127 PARTS BILL OF MATERIALS

Please confirm you have all the listed parts below **BEFORE** beginning your installation. If any parts are damaged or missing, **KEEP ALL ORIGINAL BOXES and PACKAGING** and contact us.

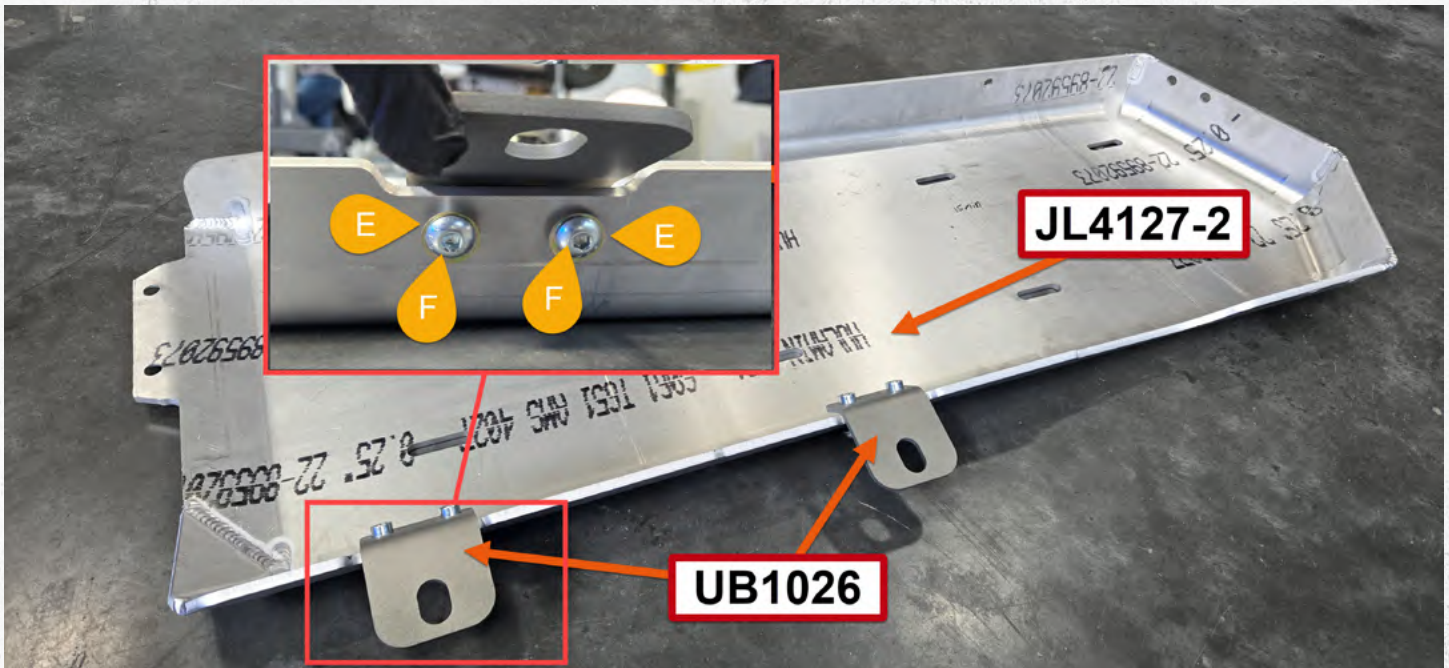


**NOTE:** The part numbers indicated above end in a “.” and “letter” which indicate the revision number for the part. The etched part number on your physical parts do not need to match the above drawing revision exactly.

## JL4127 BILL OF MATERIALS

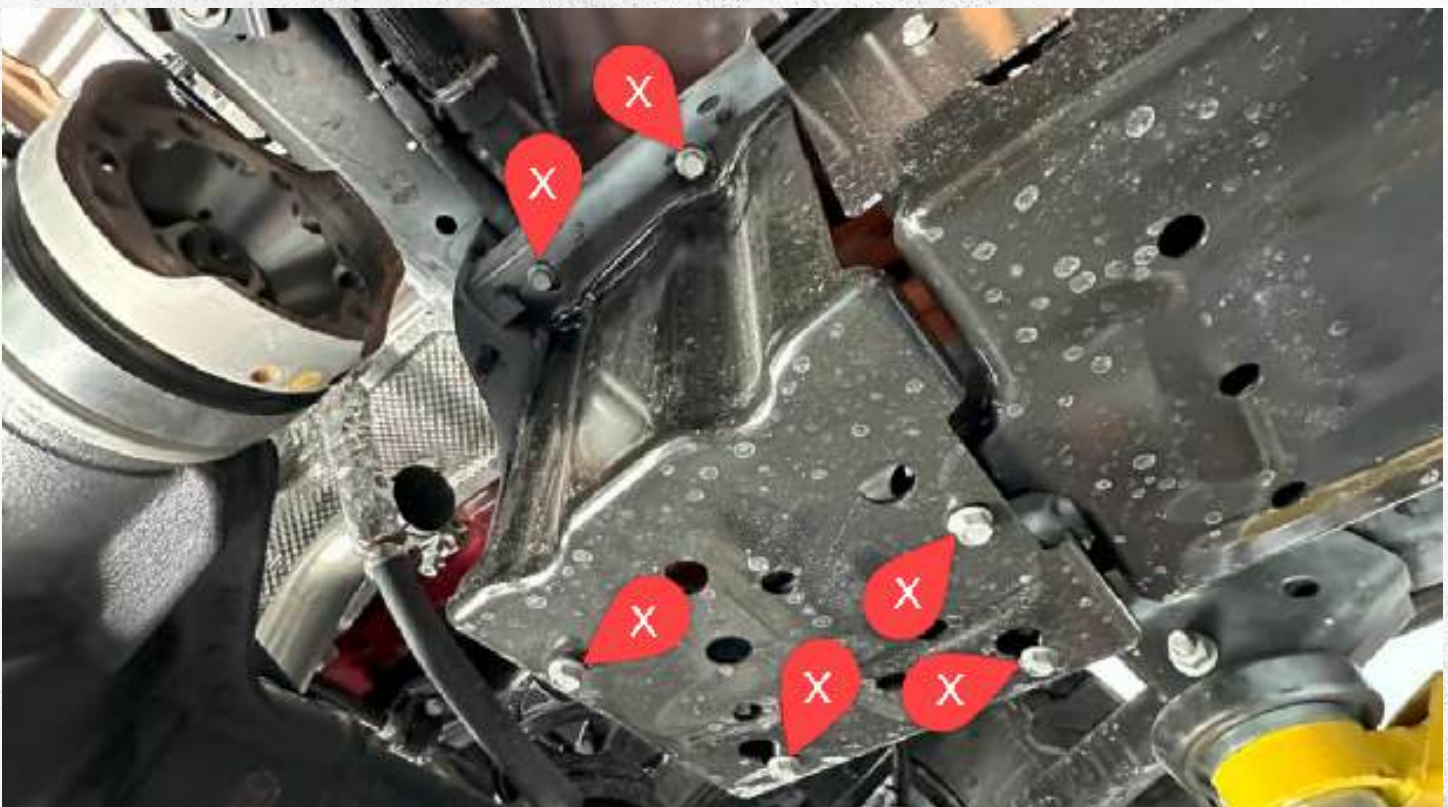
ITEM NO.	PART NUMBER	DESCRIPTION	QTY.
1	HW0101	3/8 x 16 x 1 Button Head Cap Screw Alloy Steel Zinc Plated	12
2	HW0059	3/8" Flat Washer Type 1 Yellow Zinc	13
3	HW0058	3/8"-16 x 1.0" Long Grade 8 Hex Head Cap Screw Yellow Zinc	1
4	HW0061	3/8 x 1 flat head bolt	2
5	HW0147	.375" Countersunk Aluminum Washer	2
6	HW0224	M12-1.5x40mm CUSTOM 10.9 Steel Counter Sink Allen Head Bolt - MAGNI 565 COATING	2
7	HW0062	1/4"-20 x 3/4 Button Head Socket Cap Screw Zinc Plated	2
8	HW0033	Zinc-Plated Steel USS Washer, Grade 5, for 1/4" Screw Size, 0.313" ID, 0.750" OD	2

## POWER PACK SKID PRE-INSTALL



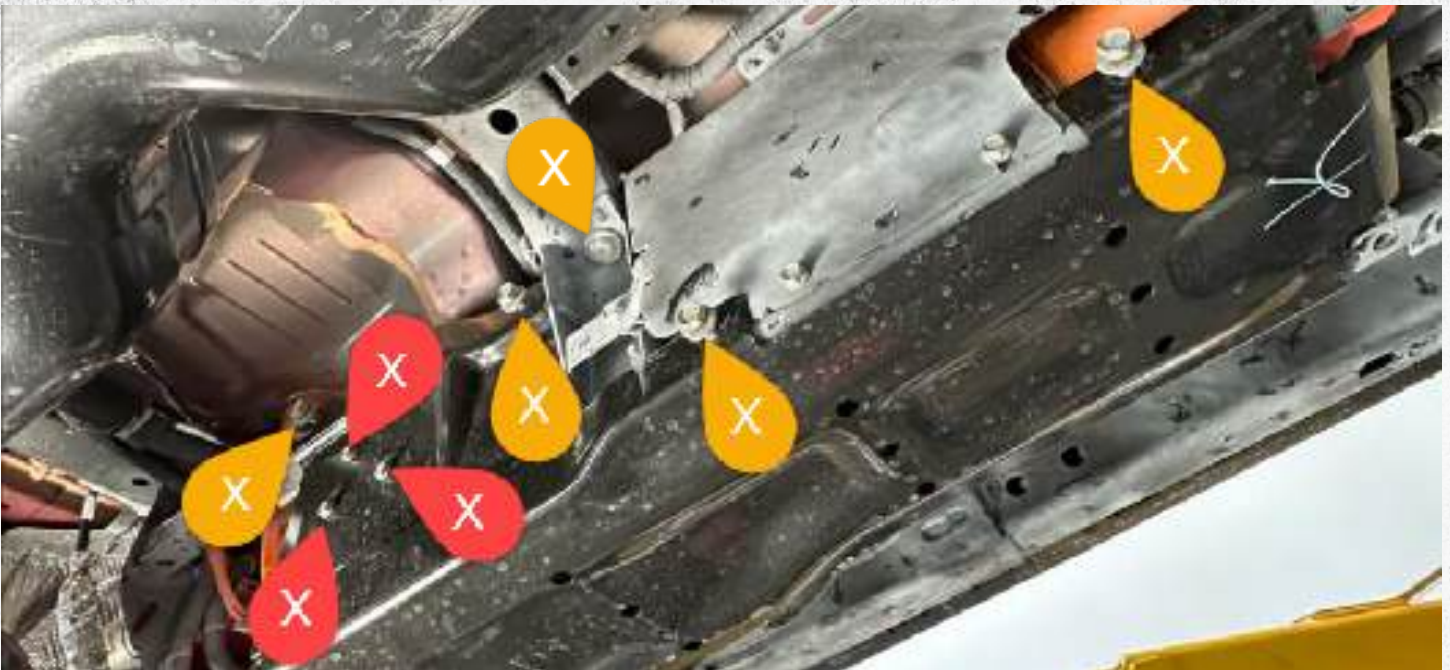
### Step 1:

Loosely install the two **UB1026** using four 3/8" x 1" button head bolts with 3/8" zinc washers.



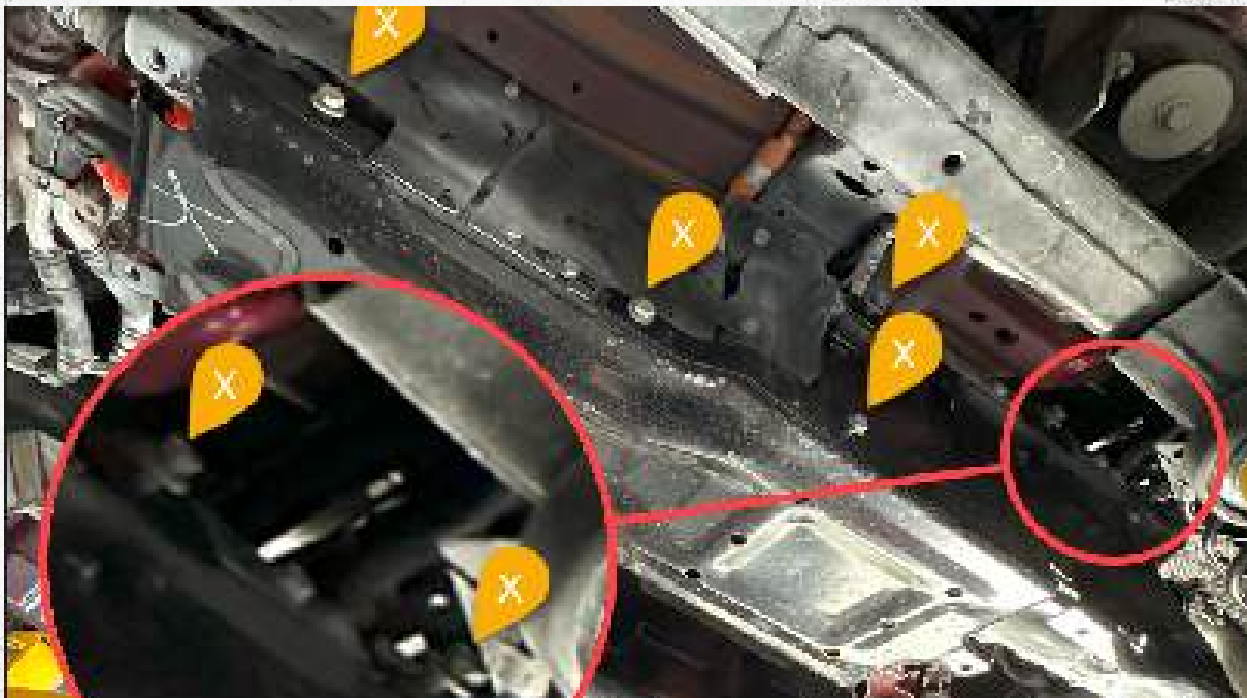
### Step 2:

Remove these six factory M6 bolts using a 10mm. **Two of these bolts will be used in the power-pack**



**Step 3:**

Remove the three factory M6 bolts **RED** and the four factory M12 bolts **YELLOW**. The three M6 bolts and two M12 bolts will be used installing the new brackets.



**Step 4:**

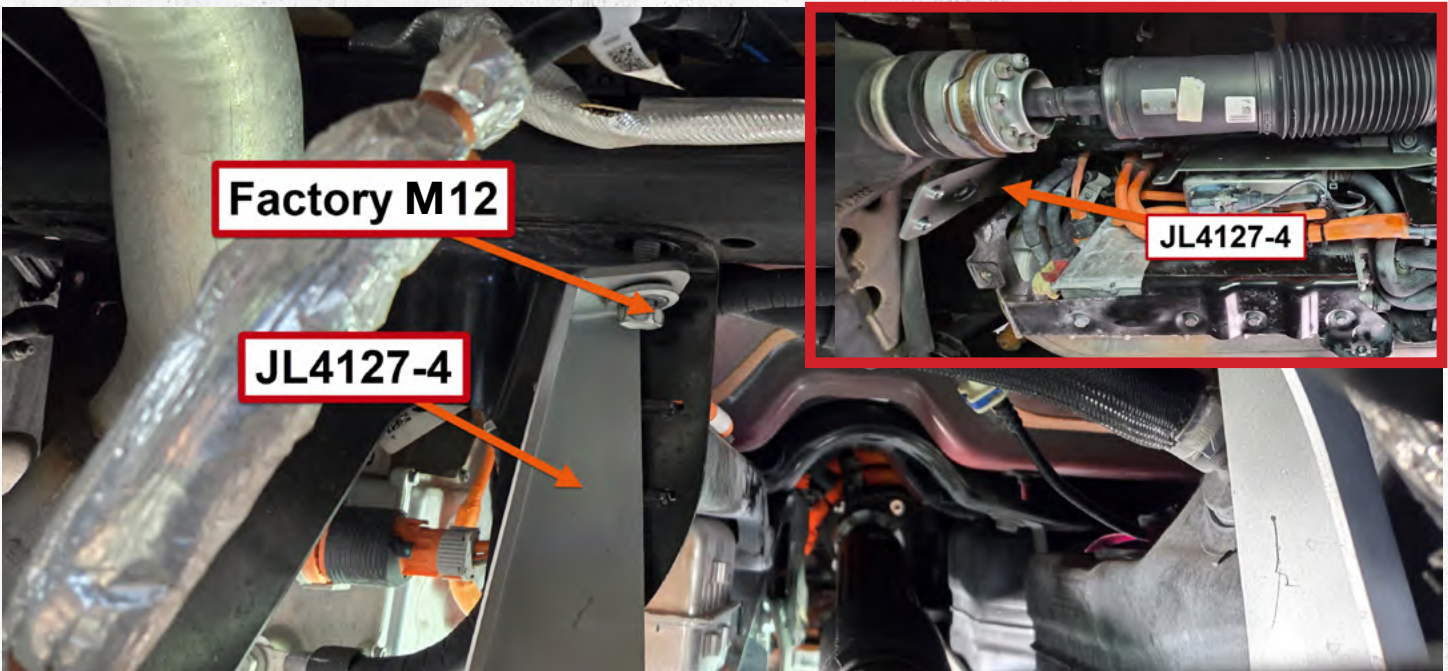
Remove the six factory M12 bolts **YELLOW**.

**These are the remaining hardware supporting the power pack skid plate, use a supporting device or a helping had to remove the last bolts and lower the factory skid-plate to the ground.**

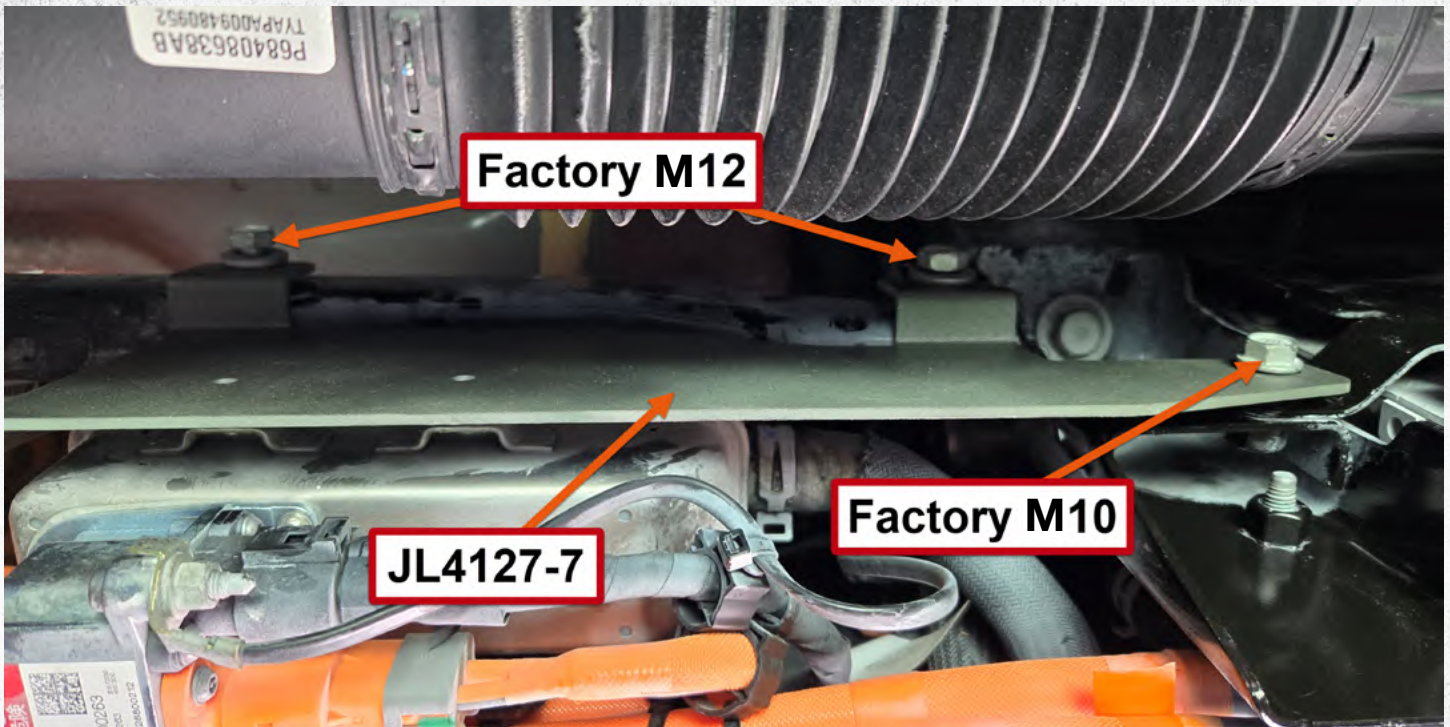


Image of the power pack skid-plate removed.

## POWER PACK SKID INSTALL

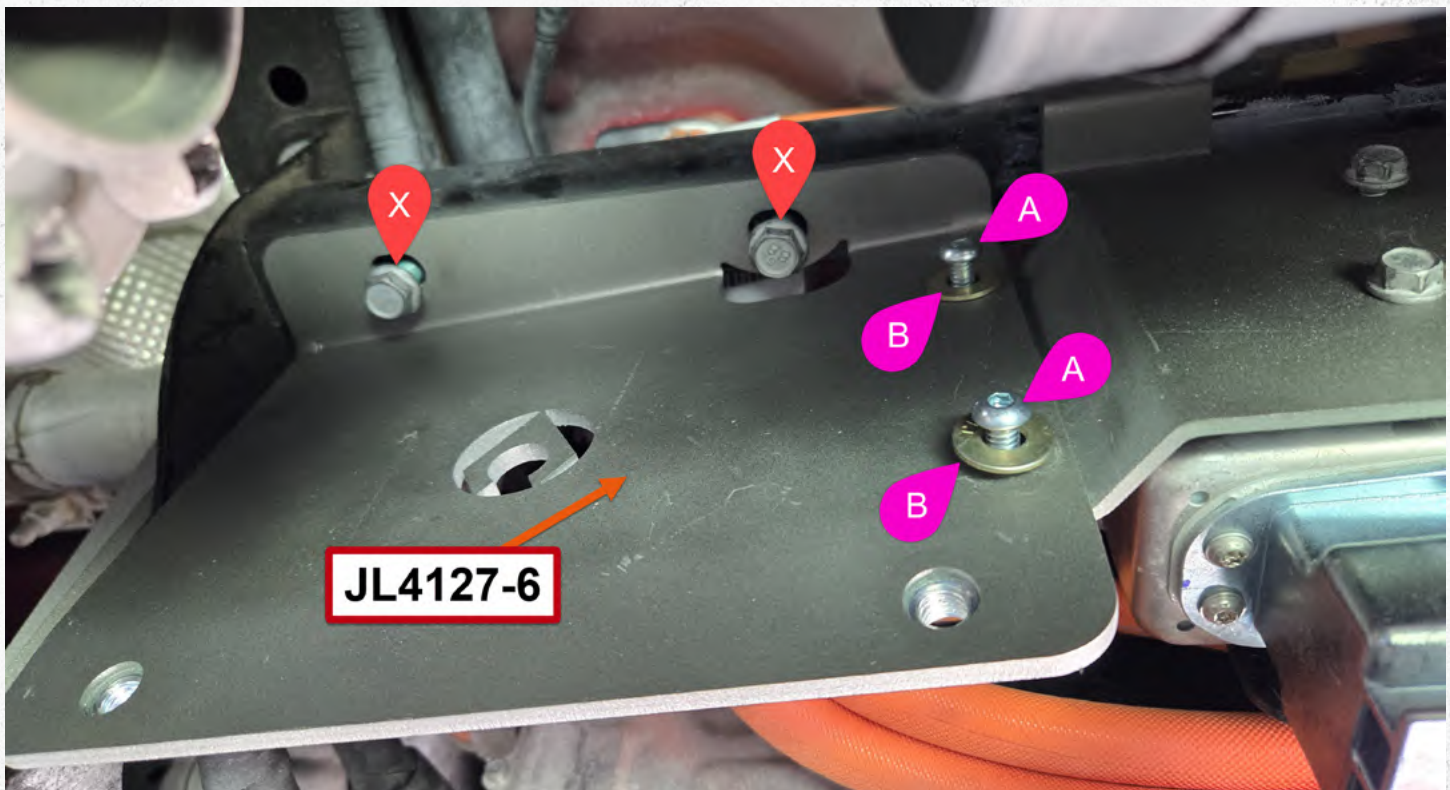


**Step 5:**  
Loosely install **JL4127-4** using a factory M12 bolt.



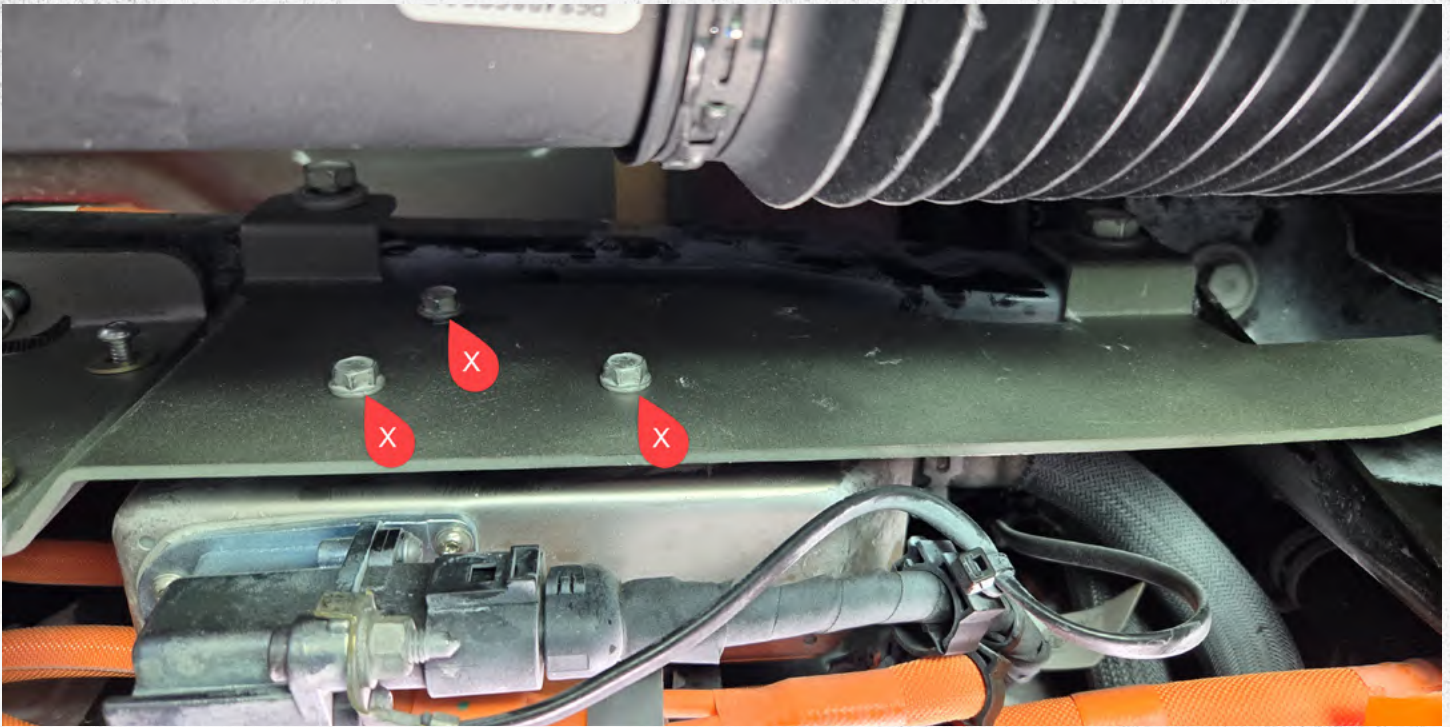
**Step 6:**

Install **JL4127-7** using two factory M12 bolts and one factory M10 bolt in there stock locations.

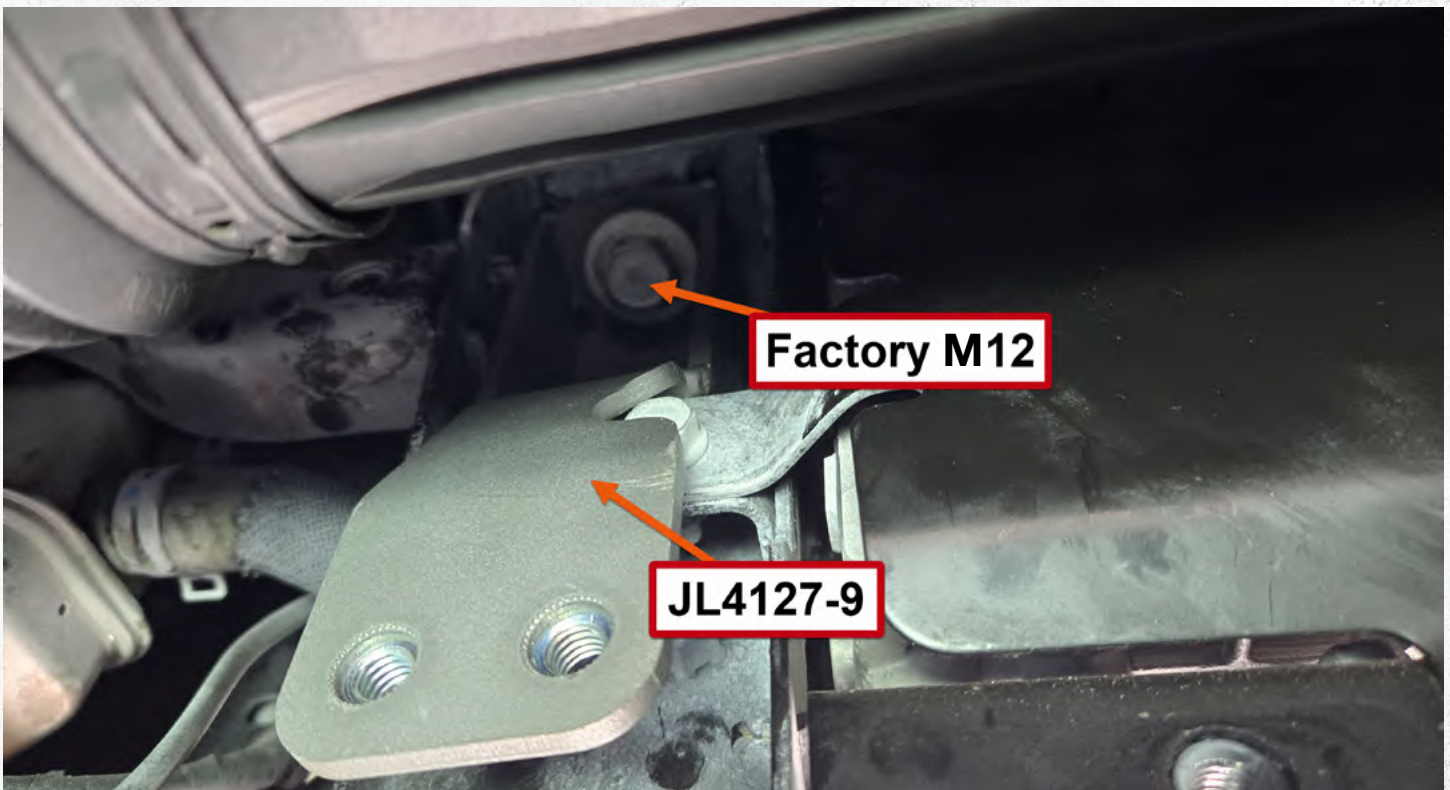


**Step 7:**

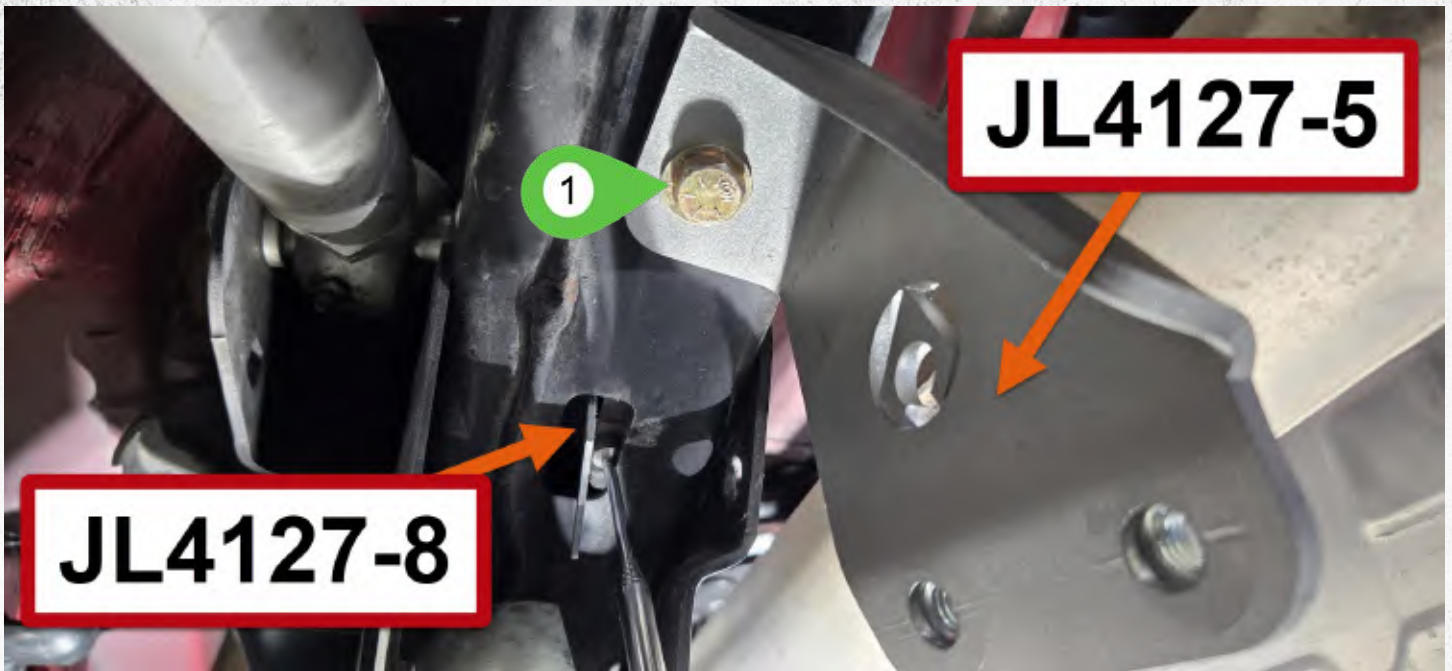
Loosely install **JL4127-6** using two 1/4 x 3/4" button head bolts with washers, next thread in the factory 10mm head bolts indicated in **RED**.



**Step 8:**  
Install the three factory M6 bolts into **JL4127-7**.

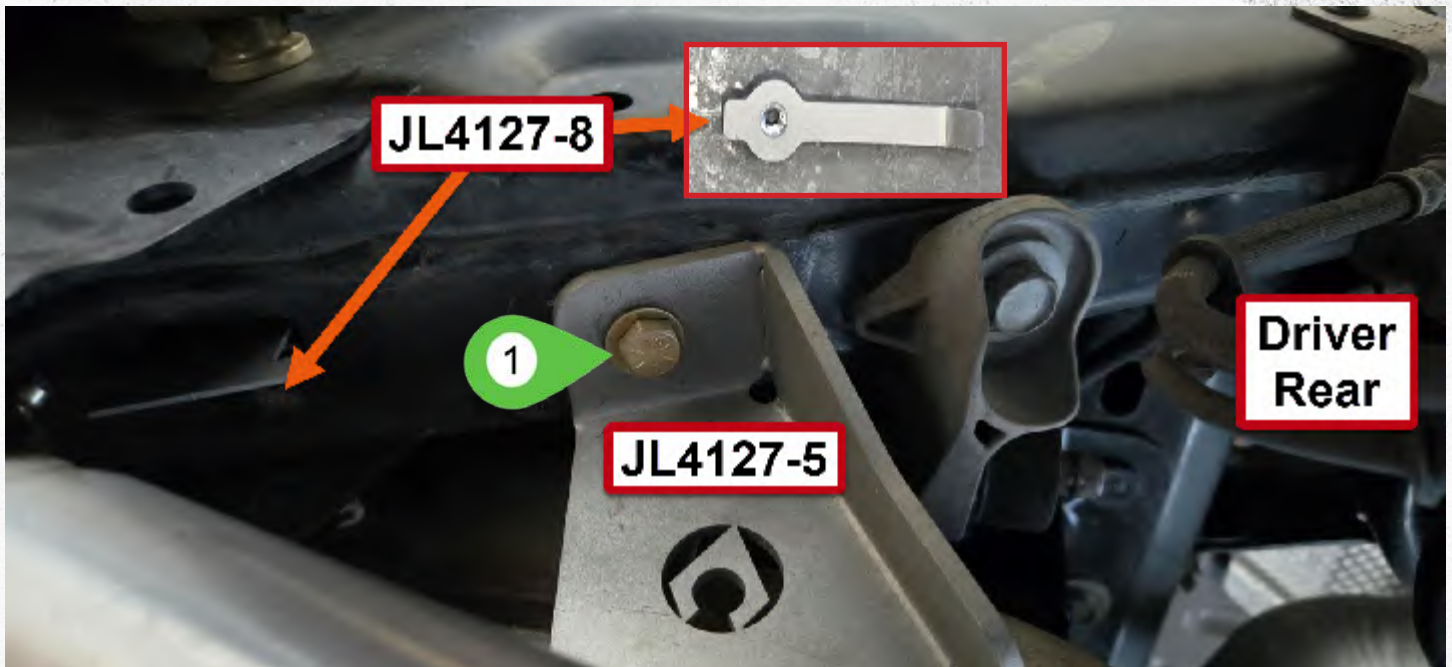


**Step 9:**  
Loosely install **JL4127-9** using a factory M12 bolt, note the notch in the bracket to allow access to tighten the bolt securing **JL4127-7**.



**Step 10:**

Install **JL4127-5** using a 3/8" grade 8 hex head bolt w/ zinc washer **GREEN 1** and a **JL4127-8** nut plate. Note in this install we used a magnet pen to hold the nut strip into place to make installation



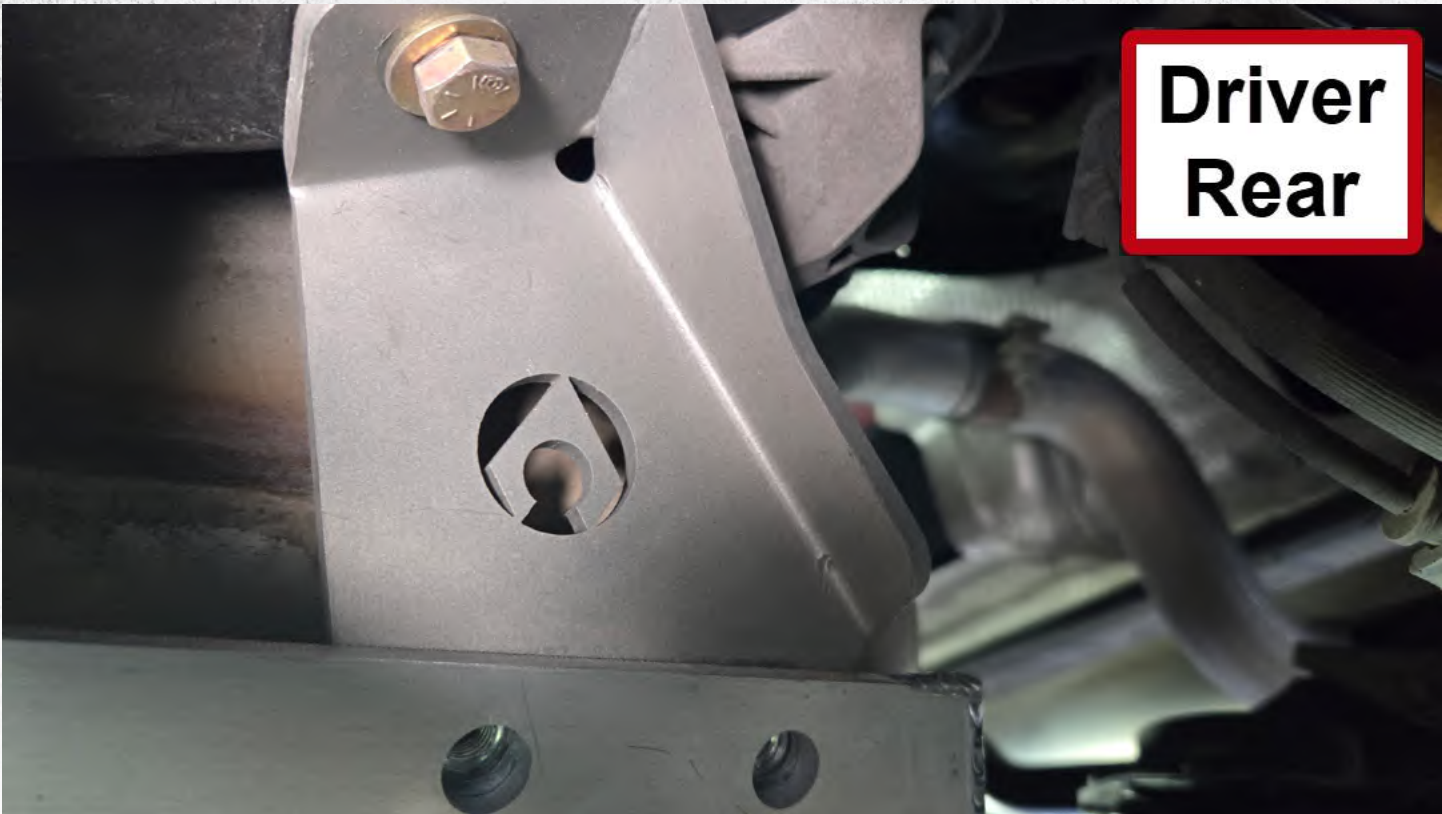


**Step 11:**

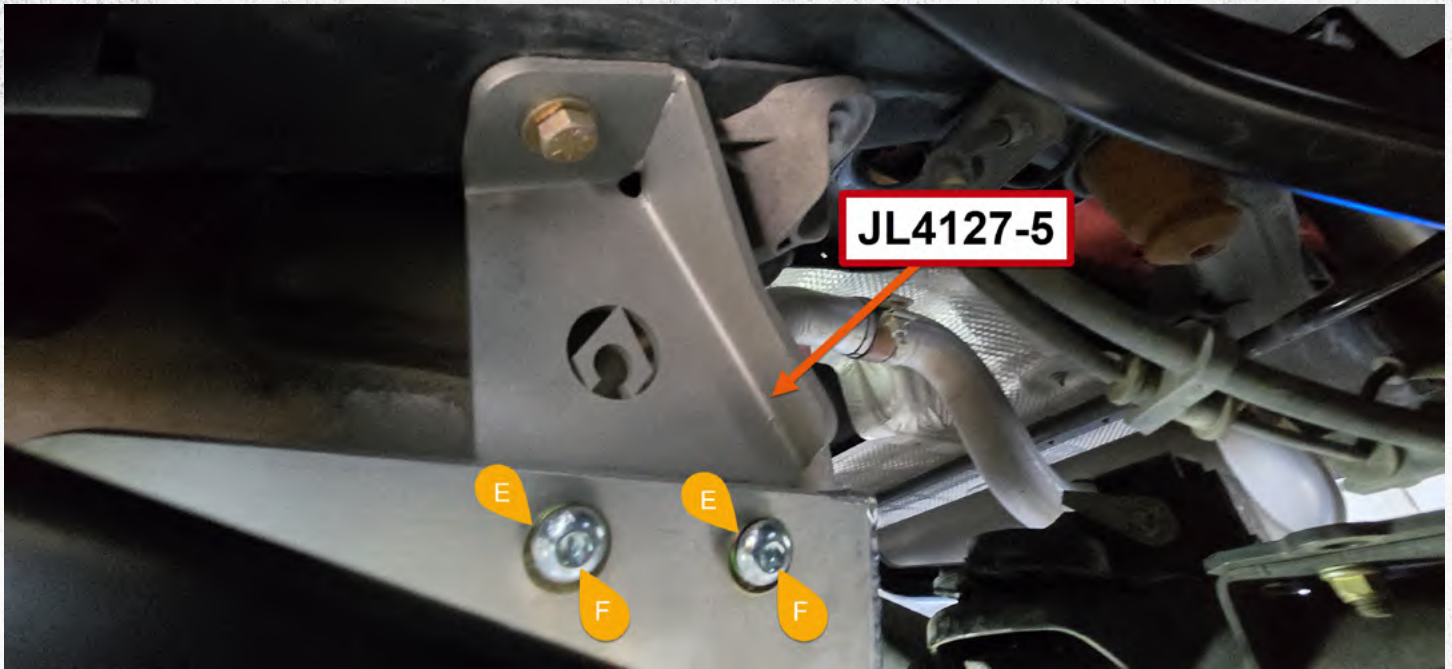
Lift and support **JL4127-2** , make sure that all brackets are still loose and are inside the skid plate.



View of step 11, Driver side of the vehicle.

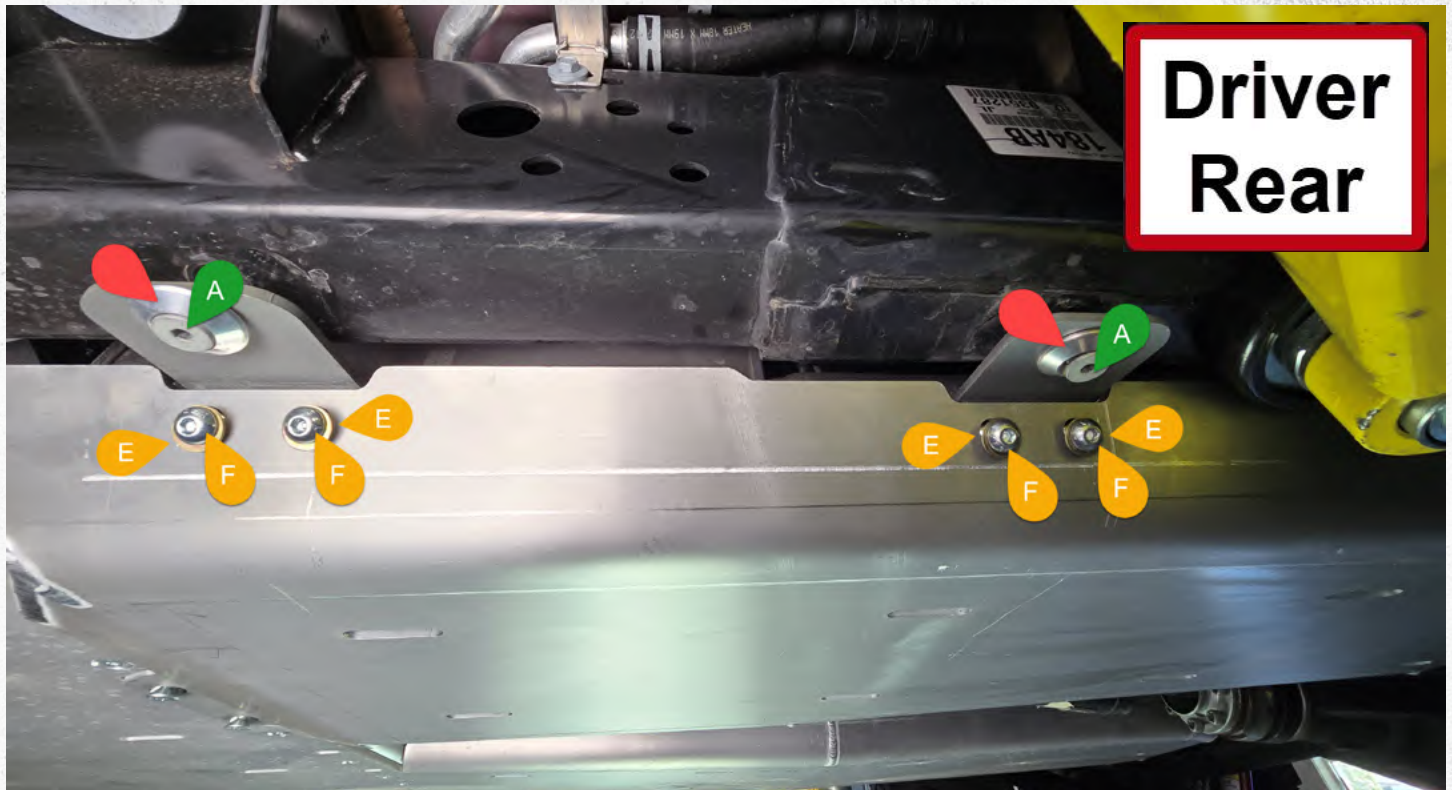


**Additional images of step 11 with the brackets loose, all of the following steps hard ware should line up and go in loosely until all bolts are installed.**



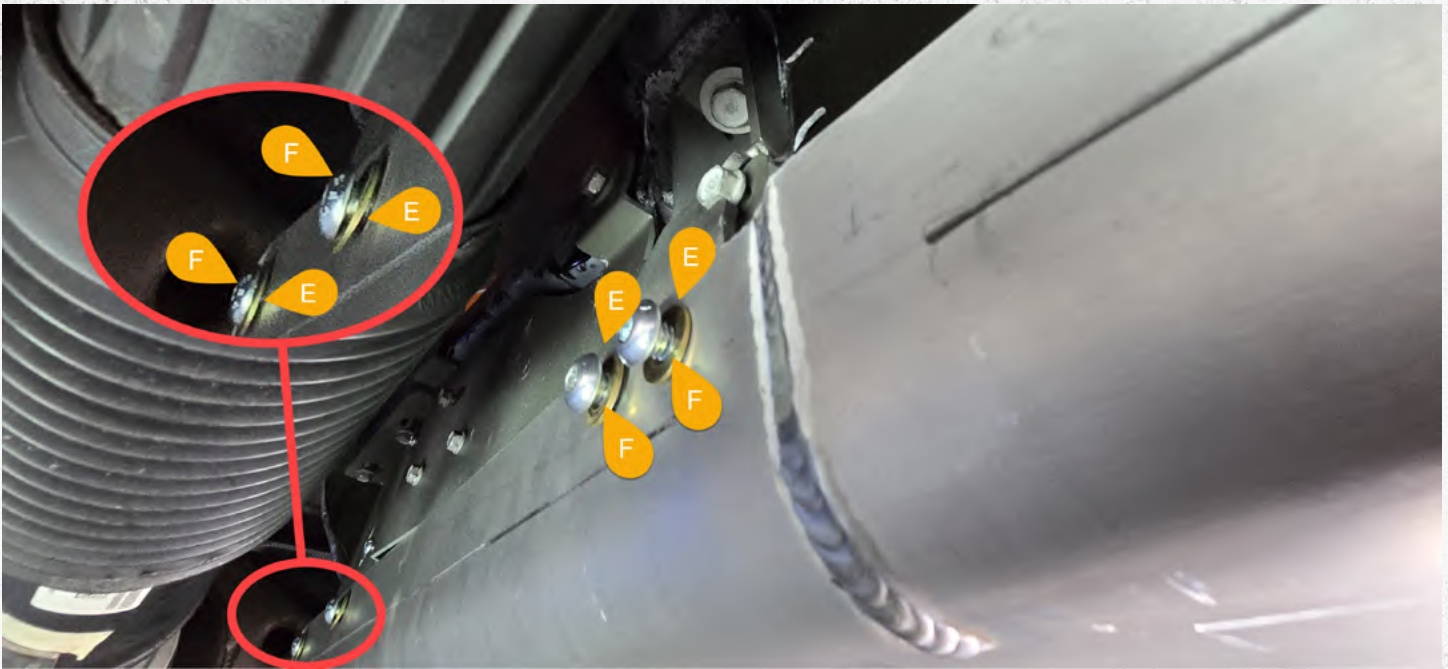
**Step 12:**

Begin installing the eight 3/8" x 1" button head bolts with zinc washers into the remaining holes.



**Step 13:**

Pictured is the installation of the 3/8" button heads with zinc washers and two M12 countersunk bolts with aluminum washers.



**Step 15:**

Additional view of the 3/8" x 1" button head bolts with zinc washers being installed into **JL4127-9**.



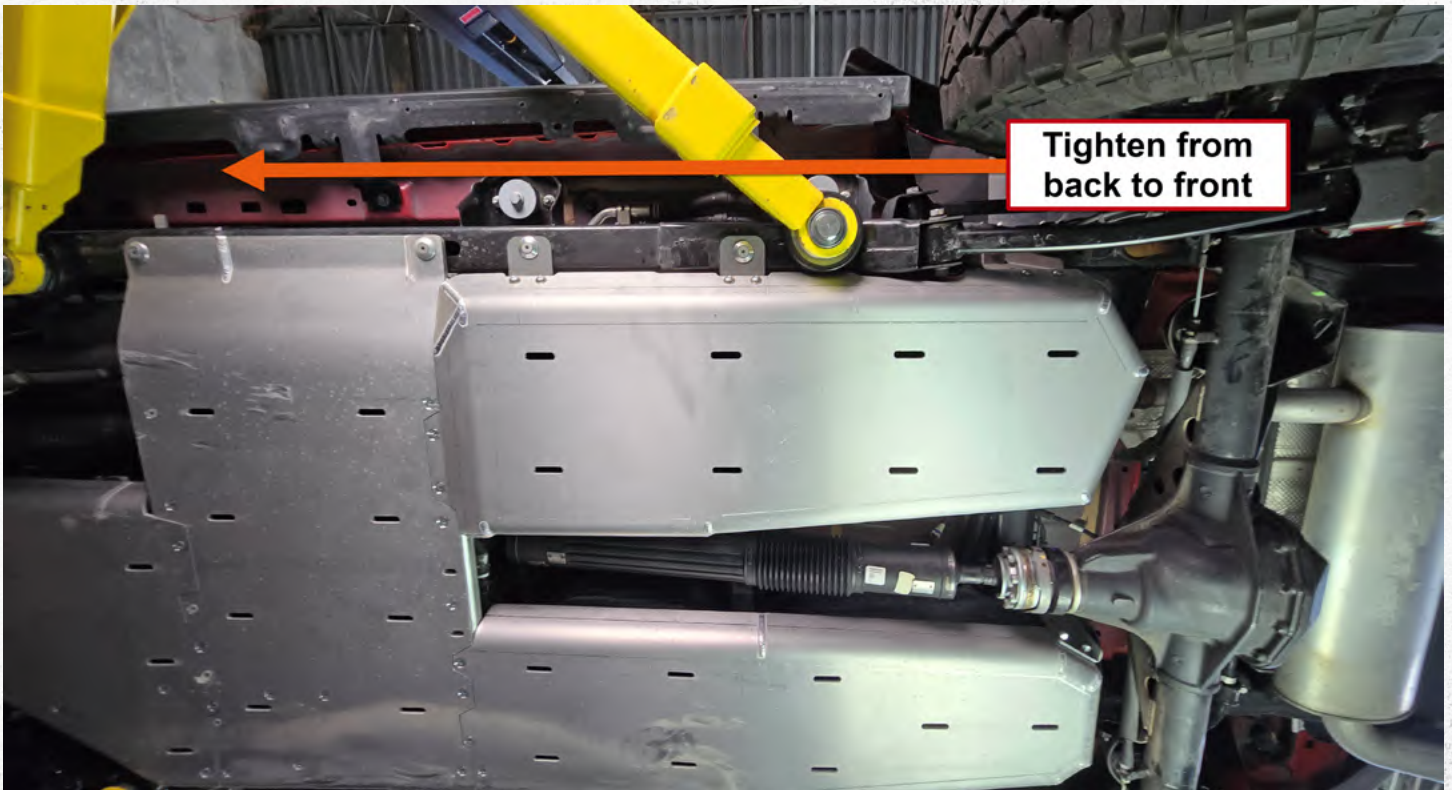
**Step 16:**

Additional view of the 3/8" x 1" button head bolts with zinc washers being installed into the rear most power pack bracket.



**Step 17:**

Install two 3/8" x 1" countersunk bolts into the new crossmember **JL4111-11**.



**Step 18:**

At this step, tighten all hardware installed with the belly pan or any hardware that was loose during the installation.



## **Verify ALL previously installed hardware is tight / torqued to specifications.**

### **CONCLUSION**

Congratulations on finishing the installation for your Artec Industries 4xE power pack skidplate. Before driving your vehicle, inspect all bolts to ensure they are properly tightened.

If you used a vehicle lift, take proper care to ensure you lower your vehicle safely.

Now take your vehicle out and enjoy the outdoors in confidence.

### **MAINTENANCE / CARE**

- After 500 miles, inspect all components and hardware to ensure they are properly fastened.
- If driving during the winter where salt is used on the roads, thoroughly and frequently wash underside of vehicle to prevent salt based corrosion.
- If removal of skid panels is required for vehicle maintenance, and bolts will not loosen, tap the bolt heads with a small sledge hammer using moderate force. This will allow the threads to loosen.
- Spray wax or similar products can be used to create a protective barrier on raw metals to protect against long term corrosion.